

STANLEY®

SPL31A SPL31A-N SPL31A-S HYDRAULIC SPIKE PULLER



SPL 31

RULE THE RAILS



USER MANUAL
Safety, Operation and Maintenance

© 2013 Stanley Black & Decker, Inc.
New Britain, CT 06053
U.S.A.
72926 3/2021 Ver. 14

NOTES

TABLE OF CONTENTS

SAFETY SYMBOLS.....	4
SAFETY PRECAUTIONS	5
TOOL STICKERS & TAGS	6
HOSE TYPES	7
HOSE RECOMMENDATIONS.....	8
HTMA / EHTMA REQUIREMENTS	9
OPERATION	10
TROUBLESHOOTING	11
SPECIFICATIONS	12
ACCESSORIES	12
HANDLE ASSEMBLY	13
PARTS ILLUSTRATION	14
PARTS LIST	15

IMPORTANT

To fill out a product warranty validation form, and for information on your warranty, visit www.stanleyinfrastructure.com and select the Company tab > Warranty.

Note: The warranty validation record must be submitted to validate the warranty.

SERVICING: This manual contains safety, operation and routine maintenance instructions. Stanley Infrastructure recommends that servicing of hydraulic tools, other than routine maintenance, must be performed by an authorized and certified dealer. Please read the following warning.

⚠ WARNING

SERIOUS INJURY OR DEATH COULD RESULT FROM THE IMPROPER REPAIR OR SERVICE OF THIS TOOL.

REPAIRS AND / OR SERVICE TO THIS TOOL MUST ONLY BE DONE BY AN AUTHORIZED AND CERTIFIED DEALER.

For the nearest certified dealer, call Stanley Infrastructure at (503) 659-5660 and ask for a Customer Service Representative.

SAFETY PRECAUTIONS

Tool operators and maintenance personnel must always comply with the safety precautions given in this manual and on the stickers and tags attached to the tool and hose.

These safety precautions are given for your safety. Review them carefully before operating the tool and before performing general maintenance or repairs.

Supervising personnel should develop additional precautions relating to the specific work area and local safety regulations. If so, place the added precautions in the space provided in this manual.

This tool will provide dependable service if operated in accordance with the instructions given in this manual. Read and understand this manual and any stickers and tags attached to the tool and hoses before operation. Failure to do so could result in personal injury or equipment damage.

- Never wear loose clothing that can become entangled in the working parts of the tool.
- Do not weld or cut the chute, handle or jaws of the tool.
- Only use accessories that conform to the specifications given in “OPERATION” on page 10.
- To avoid personal injury or equipment damage, all tool repair, maintenance and service must only be performed by authorized and properly trained personnel.
- Place the end of the chute squarely against the tie plate, tilting as required to avoid the sudden realignment that can occur as the tool begins to pull.
- Always hold the tool with both hands when the unit is running. Use a firm grip.



- The operator must start in a work area without bystanders.
- Do not operate the tool unless thoroughly trained or under the supervision of an instructor. Establish a training program for all operators to ensure safe operation.
- Always wear safety equipment such as goggles, gloves, ear and head protection and safety shoes at all times when operating the tool.
- The operator must be familiar with all prohibited work areas, such as excessive slopes and dangerous terrain conditions.
- Do not over-reach. Maintain proper footing and balance at all times.
- Do not inspect or clean the tool while the hydraulic power source is connected. Accidental engagement of the tool can cause serious injury.
- Always connect hoses to the tool hose couplers before energizing the hydraulic power source. Be sure all hose connections are tight and are in good condition.
- Do not operate the tool at oil temperatures above 140°F/60°C. Operation at higher temperatures can cause higher than normal temperatures at the tool which can result in operator discomfort.
- Do not operate a damaged, improperly adjusted or incompletely assembled tool.

TOOL STICKERS & TAGS

TG1



73019 SPL31A LOGO Decal

TG2



73020 Flow & Pressure Decal

TG3



73038 Pinch Point Warning Decal

TG4



14090 Stanley Logo Decal

NOTE:

THE INFORMATION LISTED ON THE STICKERS SHOWN, MUST BE LEGIBLE AT ALL TIMES.

REPLACE DECALS IF THEY BECOME WORN OR DAMAGED. REPLACEMENTS ARE AVAILABLE FROM YOUR LOCAL STANLEY DISTRIBUTOR.

The safety tag at right is attached to the tool when shipped from the factory. Read and understand the safety instructions listed on this tag before removal. We suggest you retain this tag and attach it to the tool when not in use.

TG5

D A N G E R

1. FAILURE TO USE HYDRAULIC HOSE LABELED AND CERTIFIED AS NON-CONDUCTIVE WHEN USING HYDRAULIC TOOLS ON OR NEAR ELECTRICAL LINES MAY RESULT IN DEATH OR SERIOUS INJURY.
BEFORE USING HOSE LABELED AND CERTIFIED AS NON-CONDUCTIVE ON OR NEAR ELECTRICAL LINES BE SURE THE HOSE IS MAINTAINED AS NON-CONDUCTIVE. THE HOSE SHOULD BE REGULARLY TESTED FOR ELECTRIC CURRENT LEAKAGE IN ACCORDANCE WITH YOUR SAFETY DEPARTMENT INSTRUCTIONS.
2. A HYDRAULIC LEAK OR BURST MAY CAUSE OIL INJECTION INTO THE BODY OR CAUSE OTHER SEVERE PERSONAL INJURY.
 - A. **DO NOT** EXCEED SPECIFIED FLOW AND PRESSURE FOR THIS TOOL. EXCESS FLOW OR PRESSURE MAY CAUSE A LEAK OR BURST.
 - B. **DO NOT** EXCEED RATED WORKING PRESSURE OF HYDRAULIC HOSE USED WITH THIS TOOL. EXCESS PRESSURE MAY CAUSE A LEAK OR BURST.
 - C. CHECK TOOL HOSE COUPLERS AND CONNECTORS DAILY FOR LEAKS. **DO NOT** FEEL FOR LEAKS WITH YOUR HANDS. CONTACT WITH A LEAK MAY RESULT IN SEVERE PERSONAL INJURY.

I M P O R T A N T

READ OPERATION MANUAL AND SAFETY INSTRUCTIONS FOR THIS TOOL BEFORE USING IT.

USE ONLY PARTS AND REPAIR PROCEDURES APPROVED BY STANLEY AND DESCRIBED IN THE OPERATION MANUAL.

TAG TO BE REMOVED ONLY BY TOOL OPERATOR.

SEE OTHER SIDE

D A N G E R

- D. **DO NOT** LIFT OR CARRY TOOL BY THE HOSES. **DO NOT** ABUSE HOSE. **DO NOT** USE KINKED, TORN OR DAMAGED HOSE.
3. **MAKE SURE** HYDRAULIC HOSES ARE PROPERLY CONNECTED TO THE TOOL BEFORE PRESSURING SYSTEM. SYSTEM PRESSURE HOSE MUST ALWAYS BE CONNECTED TO TOOL "IN" PORT. SYSTEM RETURN HOSE MUST ALWAYS BE CONNECTED TO TOOL "OUT" PORT. REVERSING CONNECTIONS MAY CAUSE REVERSE TOOL OPERATION WHICH CAN RESULT IN SEVERE PERSONAL INJURY.
4. **DO NOT** CONNECT OPEN-CENTER TOOLS TO CLOSED-CENTER HYDRAULIC SYSTEMS. THIS MAY RESULT IN LOSS OF OTHER HYDRAULIC FUNCTIONS POWERED BY THE SAME SYSTEM AND/OR SEVERE PERSONAL INJURY.
5. **BYSTANDERS** MAY BE INJURED IN YOUR WORK AREA. **KEEP BYSTANDERS** CLEAR OF YOUR WORK AREA.
6. **WEAR** HEARING, EYE, FOOT, HAND AND HEAD PROTECTION.
7. **TO AVOID** PERSONAL INJURY OR EQUIPMENT DAMAGE, ALL TOOL REPAIR MAINTENANCE AND SERVICE MUST ONLY BE PERFORMED BY AUTHORIZED AND PROPERLY TRAINED PERSONNEL.

I M P O R T A N T

READ OPERATION MANUAL AND SAFETY INSTRUCTIONS FOR THIS TOOL BEFORE USING IT.

USE ONLY PARTS AND REPAIR PROCEDURES APPROVED BY STANLEY AND DESCRIBED IN THE OPERATION MANUAL.

TAG TO BE REMOVED ONLY BY TOOL OPERATOR.

SEE OTHER SIDE

SAFETY TAG 15875 (Shown smaller than actual size)

HOSE TYPES

The rated working pressure of the hydraulic hose must be equal to or higher than the relief valve setting on the hydraulic system. There are three types of hydraulic hose that meet this requirement and are authorized for use with STANLEY hydraulic tools. They are:

Certified non-conductive — constructed of thermoplastic or synthetic rubber inner tube, synthetic fiber braid reinforcement, and weather resistant thermoplastic or synthetic rubber cover. *Hose labeled **certified non-conductive** is the only hose authorized for use near electrical conductors.*

Wire-braided (conductive) — constructed of synthetic rubber inner tube, single or double wire braid reinforcement, and weather resistant synthetic rubber cover. *This hose is **conductive** and must never be used near electrical conductors.*

Fabric-braided (not certified or labeled non-conductive) — constructed of thermoplastic or synthetic rubber inner tube, synthetic fiber braid reinforcement, and weather resistant thermoplastic or synthetic rubber cover. *This hose is **not certified non-conductive** and must never be used near electrical conductors.*

HOSE SAFETY TAGS

To help ensure your safety, the following DANGER tags are attached to all hose purchased from STANLEY. DO NOT REMOVE THESE TAGS.

If the information on a tag is illegible because of wear or damage, replace the tag immediately. A new tag may be obtained from your STANLEY Distributor.

THE TAG SHOWN BELOW IS ATTACHED TO “CERTIFIED NON-CONDUCTIVE” HOSE

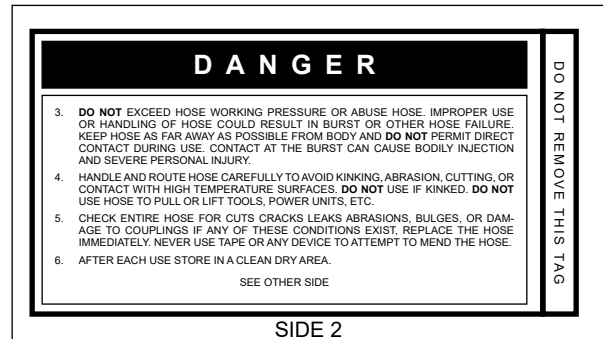
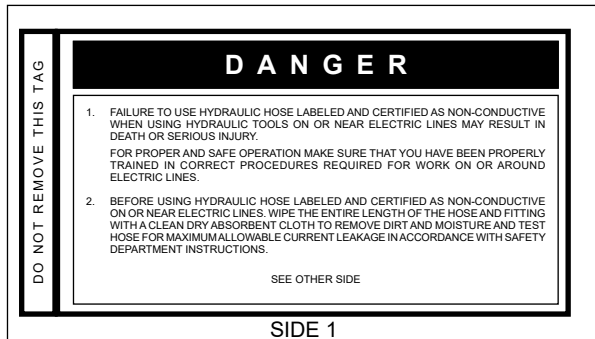

(Shown smaller than actual size)

THE TAG SHOWN BELOW IS ATTACHED TO “CONDUCTIVE” HOSE.

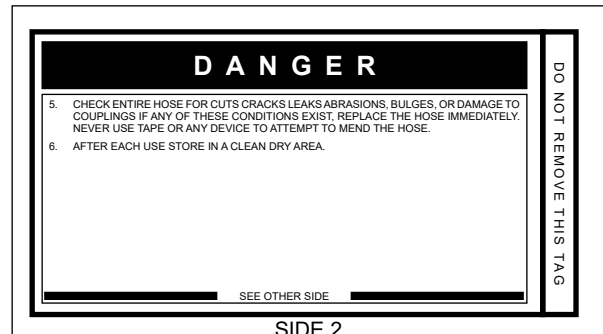
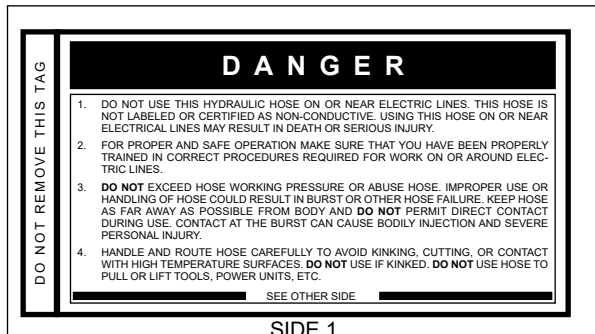

(Shown smaller than actual size)

HOSE RECOMMENDATIONS

Tool to Hydraulic Circuit Hose Recommendations

The chart to the right shows recommended minimum hose diameters for various hose lengths based on gallons per minute (GPM)/liters per minute (LPM). These recommendations are intended to keep return line pressure (back pressure) to a minimum acceptable level to ensure maximum tool performance.

This chart is intended to be used for hydraulic tool applications only based on STANLEY tool operating requirements and should not be used for any other applications.

All hydraulic hose must have at least a rated minimum working pressure equal to the maximum hydraulic system relief valve setting.

All hydraulic hose must meet or exceed specifications as set forth by SAE J517.

Oil Flow		Hose Lengths		Inside Diameter		USE (Press/Return)	Min. Working Pressure	
GPM	LPM	FEET	METERS	INCH	MM		PSI	BAR
Certified Non-Conductive Hose - Fiber Braid - for Utility Bucket Trucks								
4-9	15-34	up to 10	up to 3	3/8	10	Both	2250	155
Conductive Hose - Wire Braid or Fiber Braid - DO NOT USE NEAR ELECTRICAL CONDUCTORS								
4-6	15-23	up to 25	up to 7.5	3/8	10	Both	2500	175
4-6	15-23	26-100	7.5-30	1/2	13	Both	2500	175
5-10.5	19-40	up to 50	up to 15	1/2	13	Both	2500	175
5-10.5	19-40	51-100	15-30	5/8	16	Both	2500	175
5-10.5	19-40	100-300	30-90	5/8	16	Pressure	2500	175
10-13	38-49	up to 50	up to 15	3/4	19	Return	2500	175
10-13	38-49	51-100	15-30	5/8	16	Both	2500	175
10-13	38-49	100-200	30-60	3/4	19	Pressure	2500	175
13-16	49-60	up to 25	up to 8	1	25.4	Return	2500	175
13-16	49-60	26-100	8-30	5/8	16	Pressure	2500	175
				3/4	19	Return	2500	175
				3/4	19	Pressure	2500	175
				1	25.4	Return	2500	175

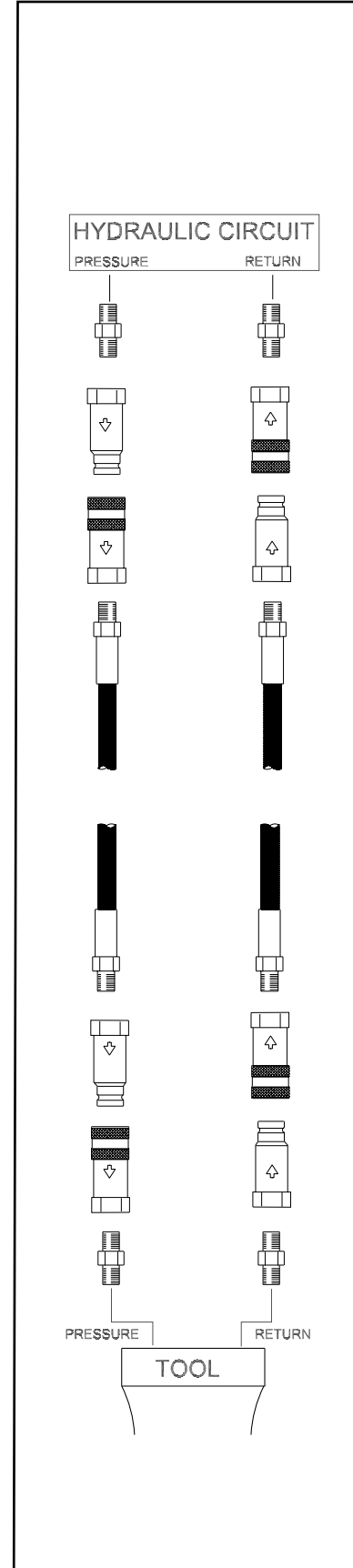

Figure 1. Typical Hose Connections

HTMA / EHTMA REQUIREMENTS

HTMA / EHTMA REQUIREMENTS

TOOL TYPE

HTMA HYDRAULIC SYSTEM REQUIREMENTS	TYPE I	TYPE II	TYPE RR	TYPE III
Flow range	4-6 GPM (15-23 LPM)	7-9 GPM (26-34 LPM)	9-10.5 GPM (34-40 LPM)	11-13 GPM (42-49 LPM)
Nominal operating pressure (At the power supply outlet)	1500 psi (103 bar)	1500 psi (103 bar)	1500 psi (103 bar)	1500 psi (103 bar)
System relief valve setting (At the power supply outlet)	2100-2250 psi (145-155 bar)	2100-2250 psi (145-155 bar)	2200-2300 psi (152-159 bar)	2100-2250 psi (145-155 bar)
Maximum back pressure (At tool end of the return hose)	250 psi (17 bar)	250 psi (17 bar)	250 psi (17 bar)	250 psi (17 bar)
Measured at a max fluid viscosity of: (At minimum operating temperature)	400 ssu* (82 centistokes)	400 ssu* (82 centistokes)	400 ssu* (82 centistokes)	400 ssu* (82 centistokes)
Temperature: Sufficient heat rejection capacity to limit maximum fluid temperature to: (At maximum expected ambient temperature)	140° F (60° C)	140° F (60° C)	140° F (60° C)	140° F (60° C)
Minimum cooling capacity at a temperature difference of between ambient and fluid temps	3 hp (2.24 kW) 40° F (22° C)	5 hp (3.73 kW) 40° F (22° C)	6 hp (5.22 kW) 40° F (22° C)	7 hp (4.47 kW) 40° F (22° C)
Note: Do not operate the tool at oil temperatures above 140° F (60° C). Operation at higher temperatures can cause operator discomfort at the tool.				
Filter minimum full-flow filtration Sized for flow of at least: (For cold temp startup and maximum dirt-holding capacity)	25 microns 30 GPM (114 LPM)	25 microns 30 GPM (114 LPM)	25 microns 30 GPM (114 LPM)	25 microns 30 GPM (114 LPM)
Hydraulic fluid, petroleum based (premium grade, anti- wear, non-conductive) Viscosity (at minimum and maximum operating temps)	100-400 ssu (20-82 centistokes)	100-400 ssu (20-82 centistokes)	100-400 ssu (20-82 centistokes)	100-400 ssu (20-82 centistokes)
Note: When choosing hydraulic fluid, the expected oil temperature extremes that will be experienced in service determine the most suitable temperature viscosity characteristics. Hydraulic fluids with a viscosity index over 140 will meet the requirements over a wide range of operating temperatures.				
*SSU = Saybolt Seconds Universal				

CLASSIFICATION

EHTMA HYDRAULIC SYSTEM REQUIREMENTS					
Flow range	3.5-4.3 GPM (13.5-16.5 LPM)	4.7-5.8 GPM (18-22 LPM)	7.1-8.7 GPM (27-33 LPM)	9.5-11.6 GPM (36-44 LPM)	11.8-14.5 GPM (45-55 LPM)
Nominal operating pressure (At the power supply outlet)	1870 psi (129 bar)	1500 psi (103 bar)	1500 psi (103 bar)	1500 psi (103 bar)	1500 psi (103 bar)
System relief valve setting (At the power supply outlet)	2495 psi (172 bar)	2000 psi (138 bar)	2000 psi (138 bar)	2000 psi (138 bar)	2000 psi (138 bar)

Note: These are general hydraulic system requirements. See tool specification page for tool specific requirements.

OPERATION

CHECK HYDRAULIC POWER

SOURCE

1. Using a calibrated flowmeter and pressure gauge, check that the hydraulic power source develops a flow of 5-10.5 GPM/15-40 LPM at 2000 psi/140 bar.
2. Make certain the hydraulic power source is equipped with a relief valve set to a max of 2500 psi/172 bar.
3. Check that the hydraulic circuit matches the tool for open center (OC) operation.

CHECK TOOL

1. Make sure all tool accessories are correctly installed. Failure to install tool accessories properly can result in damage to the tool or personal injury.
2. There should be no signs of leaks.
3. The tool should be clean, with all fittings and fasteners tight.

CHECK TRIGGER MECHANISM

1. Check that the trigger operates smoothly and is free to travel between the "ON" and "OFF" positions.

CONNECT HOSES

1. Wipe all hose couplers with a clean lint-free cloth before making connections.
2. Connect the hoses from the hydraulic power source to the hose couplers on the Spike Puller. It is a good practice to connect the return hose first and disconnect it last to minimize or avoid trapped pressure within the system.
3. Observe flow indicators stamped on hose couplers to be sure that oil will flow in the proper direction. The female coupler is the inlet coupler.

NOTE: The pressure increase in uncoupled hoses left in the sun may result in making them difficult to connect. When possible, connect the free ends of operating hoses together.

OPERATING PROCEDURES

1. Observe all safety precautions.
2. Move the hydraulic circuit control valve to the ON

position.

3. Place the spike puller firmly over the spike to be pulled making sure the end of the chute is in full contact with the spike plate.

SPL31A

1. The SPL31A has an automatic pull cycle that engages the spike and sets the tool to the rail at a slow speed; then fully removes the spike at a higher speed, the cycle is automatic, and operates by fully depressing the trigger.
2. At the top of the stroke release the trigger and the spike will automatically be ejected from the puller.

COLD WEATHER OPERATION

If the spike puller is to be used during cold weather, preheat the hydraulic fluid at low engine speed. When using the normally recommended fluids, fluid temperature should be at or above 50° F/ 10° C (400 ssu/82 centistokes) before use.

TROUBLESHOOTING

If symptoms of poor performance develop, the following chart can be used as a guide to correct the problem.

When diagnosing faults in operation of the spike puller, always check that the hydraulic power source is supplying the correct hydraulic flow and pressure to the spike driver as listed in the table. Use a flowmeter known to be accurate. Check the flow with the hydraulic oil temperature at least 80 °F/27 °C.

Problem	Cause	Solution
Spike puller does not cycle.	Hydraulic power source not functioning correctly.	Check power source for proper flow and pressure (5-10 GPM/19-34 LPM, 2500 psi/172 bar).
	Coupler or hoses blocked.	Remove obstruction.
	Pressure and return line hoses reversed at ports.	Be sure hoses are connected to their proper ports.
Spike puller does not pull effectively.	Hydraulic power source not functioning correctly.	Check power source for proper flow and pressure (5-10 GPM/19-34 LPM, 2500 psi/172 bar).
	Couplers or hose blocked.	Remove restriction.
	Fluid too hot (above 140 °F/60 °C).	Provide cooler to maintain proper fluid temperature.
	The jaw is not sliding freely in the chute.	Remove, clean and replace as required.
Spike puller operates slow.	Low oil flow from power unit.	Check power source for proper flow and oil level.
	High back pressure.	Check hydraulic system for excessive back pressure and correct as required.
	Couplers or hoses blocked.	Remove obstruction.
Jaw re-tracked with tool in neutral position	Pressure and return lines reversed at ports.	Be sure hoses are connected to their proper ports.

NOTICE

In addition to the Safety Precautions found in this manual, observe the following for equipment protection and care.

- Always store an idle tool in a clean dry space, safe from damage or pilferage.
- Do not exceed the rated limits or use the tool for applications beyond its design capacity.
- Always keep critical tool markings, such as labels and warning stickers, legible.
- Always replace hoses, couplings and other parts with replacement parts recommended by Stanley.
- Supply hoses must have a minimum working pressure rating of 2500 psi/175 bar.
- Permit only experienced personnel to perform tool repair.
- Be sure to wipe all couplers clean before connecting. Use only lint-free cloths.
- The hydraulic circuit control valve must be in the **OFF** position when coupling or uncoupling the tool. Failure to do so may result in damage to the quick couplers and cause overheating of the hydraulic system.
- Check fastener tightness often and before each use daily.

SPECIFICATIONS

Pulling Force.....	16,647 lbs / 7550 kg
Pressure	2500 psi/172 bar
Maximum Back Pressure.....	250 psi/17 bar
Flow Range	5-10 GPM / 19-38 LPM HTMA Type I - II, RR
Porting	-8 SAE O-Ring
Couplers	HTMA/EHTMA Flush Face Type Male and Female
Connect Size and Type	3/8 Male Pipe Adapter
Weight (without hose whips & couplers) (with oil)	31 lb / 14.0 kg
Overall Length	32.75 inches / 83.1 cm
Overall Handle Width.....	16.25 inches / 41.2 cm
Overall Height.....	5.25 inches / 13.3 cm
Maximum Fluid Temperature	140° F/60° C

ACCESSORIES

Hair Pin "W" Grip Jaw (2 Required).....	34876
---	-------

HANDLE ASSEMBLY

**SPL31A
SPL31A-N
SPL31A-S**

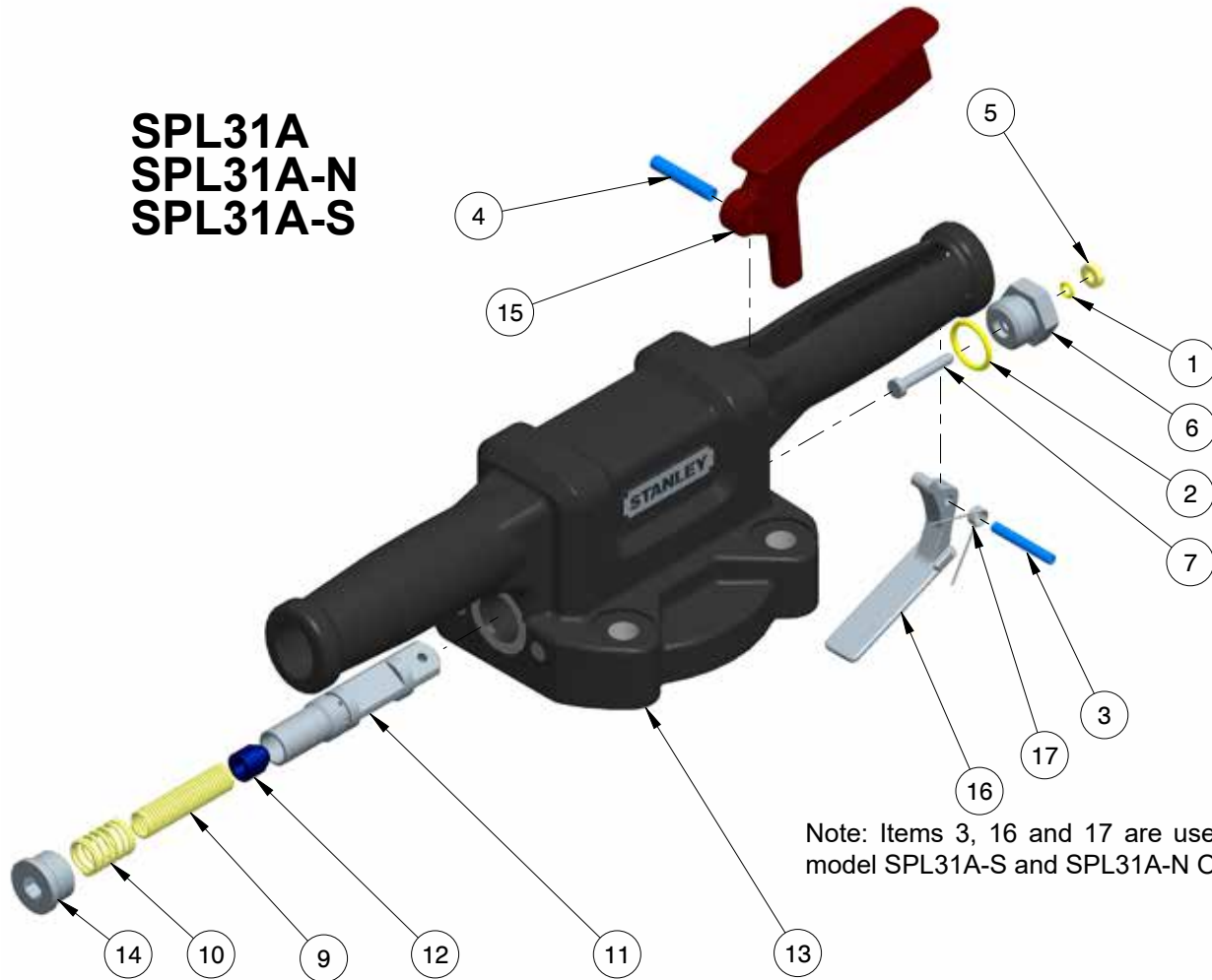

Note: Items 3, 16 and 17 are used on model SPL31A-S and SPL31A-N Only.

* DENOTES PART IN SEAL KIT
SEAL KIT 73042

ITEM	PART NO.	QTY	DESCRIPTION
1	00026	1	O-RING* (PART OF SEAL KIT)
2	01604	1	O-RING* (PART OF SEAL KIT)
3	03009	1	ROLL PIN (SPL31A-S, SPL31A-N ONLY)
4	21089	1	ROLL PIN
5	22064	1	ROD WIPER* (PART OF SEAL KIT)
6	22914	1	SPOOL SEAL CAP
7	22919	1	HEADED TRIGGER
9	35404	1	COMPRESSION COIL SPRING
10	35421	1	COMPRESSION COIL SPRING
11	72888	1	RELIEVING VALVE SPOOL
12	72890	1	RELIEF POPPET
13	73043	1	SPIKE PULLER HANDLE WITH EXPANDER PLUGS INSTALLED
14	73021	1	SAE ORB PLUG MODIFIED
15	73035	1	TRIGGER ANODIZED PAINTED
16	73070	1	SAFETY TRIGGER (SPL31A-S, SPL31A-N ONLY)
17	73171	1	TORSION SPRING (SPL31A-S, SPL31A-N ONLY)

PARTS ILLUSTRATION

SEE PAGE 6 FOR DECAL P/N's

**SPL31A
SPL31A-N
SPL31A-S**

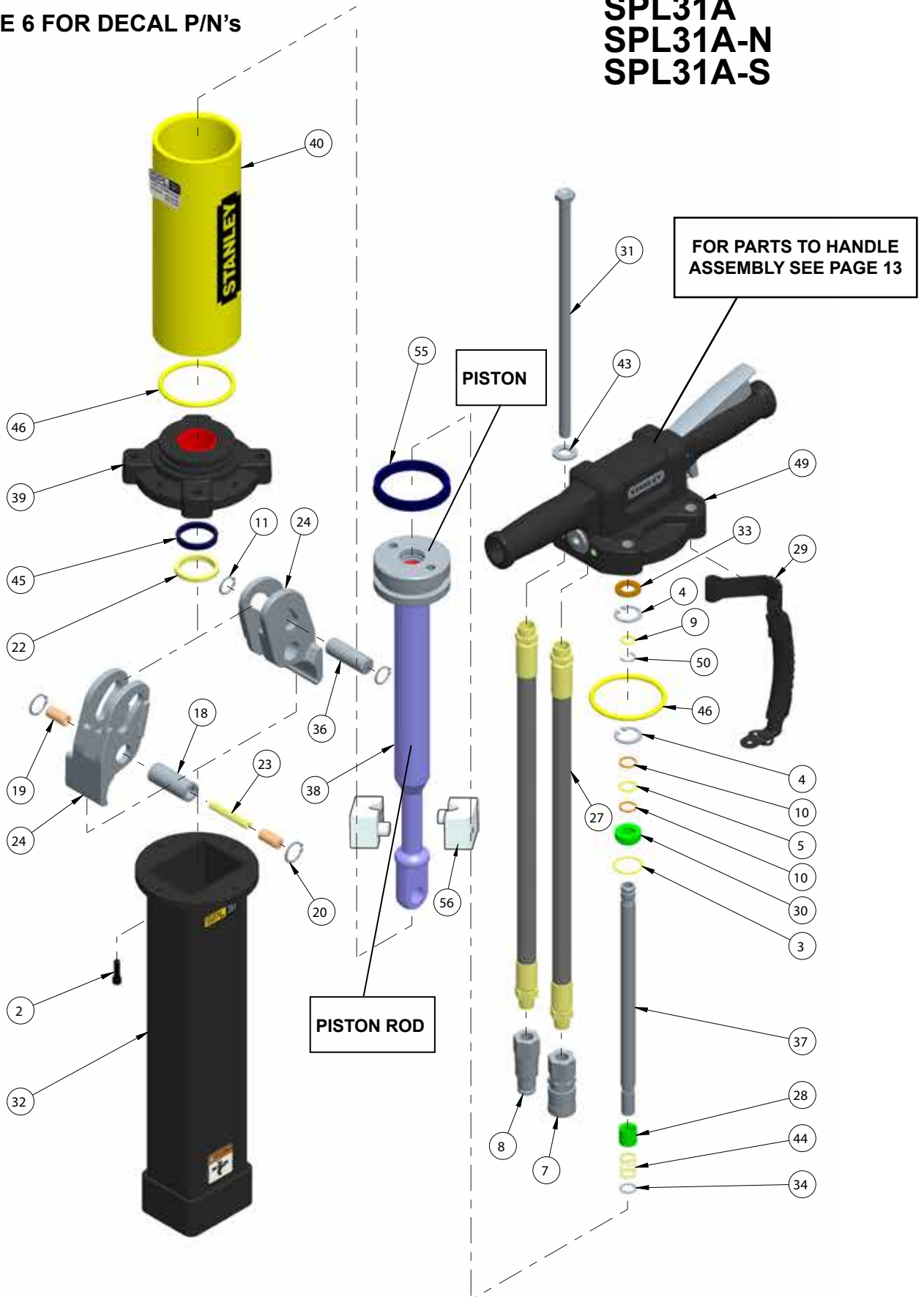

PARTS LIST

SPL31A / SPL31A-N / SPL31A-S

ITEM	P/N.	QTY.	DESCRIPTION
2	00596	4	CAPSCREW
3	00138	1	O-RING* (PART OF SEAL KIT)
4	00664	2	RETAINING RING
5	01211	1	O-RING* (PART OF SEAL KIT)
7	03972	1	COUPLER,FEMALE 3/8NPT FL.FACE SET P/N-03971 (SP- L31A AND SPL31A-S ONLY)
	81158	1	COUPLER,FEMALE 3/8NPT FL.FACE SET P/N-81160 (SP- L31A-N ONLY)
8	03973	1	COUPLER,MALE 3/8NPT FL.FACE SET P/N-03971 (SP- L31A AND SPL31A-S ONLY)
	81159	1	COUPLER,MALE 3/8NPT FL.FACE SET P/N-81160 (SP- L31A-N ONLY)
9	04911	1	O-RING* (PART OF SEAL KIT)
10	08015	2	BACK-UP RING* (PART OF SEAL KIT)
11	09275	2	RETAINING RING EXTERNAL
18	25992	1	JAW PIVOT SLEEVE
19	26388	2	SPRING CUP* (PART OF SEAL KIT)
20	26812	2	RETAINING RING EXTERNAL
22	32094	1	ROD WIPER* (PART OF SEAL KIT)
23	32097	1	COMPRESSION COIL SPRING
24	82791	2	GRIP JAW CASTING
27	56725	2	HOSE ASSY (SPL31A and SPL31A-S ONLY)
	66727	2	HOSE ASSY (SPL31A-N ONLY)
28	71942	1	CHECK VALVE
29	72537	1	SPL31 AUX HANDLE
30	72538	1	PISTON INSERT
31	72540	4	CAPSCREW
32	73044	1	CHUTE, SUB-ASSY (INCLUDES PAINT & DECALS)
33	72552	1	ALUMINUM WASHER
34	72554	1	EXTERNAL INVERTED RET RING
36	72853	1	JAW PIN
37	72854	1	OIL TUBE

ITEM	P/N.	QTY.	DESCRIPTION
38	72883	1	SPL31A ROD ASSEMBLY (IN- CLUDES ITEM 55)
39	72884	1	LOWER CYLINDER HEAD (INCLUDES BEARING & HELI- COILS)
40	73045	1	CYLINDER, SUB-ASSY (IN- CLUDES PAINT & DECALS)
43	72892	4	WASHER
44	72894	1	COMPRESSION COIL SPRING
45	72895	1	PISTON ROD SEAL* (PART OF SEAL KIT)
46	72897	2	O-RING* (PART OF SEAL KIT)
49	73043	1	SPIKE PULLER HANDLE WITH EXPANDER PLUGS INSTALLED (SEE PAGE 13 FOR PARTS)
50	73010	1	C SHAFT RINGS* (PART OF SEAL KIT)
55	72535	1	PISTON SEAL* (INCLUDED WITH ITEM 38 AND ALSO PART OF SEAL KIT)
56	81565	2	GUIDE HALF NOTE: ONLY USED ON OLDER MODELS WITH ALUMINUM CHUTES.
SK1	73042	1	SEAL KIT (* DENOTES PART IN SEAL KIT)

STANLEY®

Stanley Infrastructure
3810 SE Naef Road
Milwaukie, Oregon 97267-5698 USA
(503) 659-5660 / Fax (503) 652-1780
www.stanleyinfrastructure.com