

STANLEY®

MBX138 - MBX608 HYDRAULIC MOUNTED BREAKERS



MBX138 thru
MBX608

USER MANUAL
Safety, Operation and Maintenance



© 2014 STANLEY
Milwaukie, OR 97267 USA
36098 04/2024 Ver. 29

DECLARATION OF CONFORMITY

STANLEY
Hydraulic Tools

DECLARATION OF CONFORMITY
ÜBEREINSTIMMUNGS-ERKLÄRUNG
DECLARATION DE CONFORMITE CEE
DECLARACION DE CONFORMIDAD
DICHIARAZIONE DI CONFORMITA
DECLARAÇÃO DE CONFORMIDADE



I, the undersigned:
Ich, der Unterzeichnende:
Je soussigné:
El abajo firmante:
Io sottoscritto:
Eu, abaixo assinado

Weisbeck, Andy

Surname and First names/Familienname und Vornamen/Nom et prénom/Nombre y apellido/Cognome e nome

hereby declare that the equipment specified hereunder:
bestätige hiermit, daß erklaren Produkt genannten Werk oder Gerät:
déclare que l'équipement visé ci-dessous:
Por la presente declaro que el equipo se especifica a continuación:
Dichiaro che le apparecchiature specificate di seguito:
Através deste, declaro que os equipamentos especificados abaixo

- Category/Kategorie/Catégorie/Categoria: **Mounted Hydraulic Breaker**
- Make/Marke/Marque/Marca/Marca/: **Stanley**
- Type/Typ/Type/Tipo/: **MBX138, MBX208, MBX258, MBX308, MBX358, MBX408, MBX458 and MBX608**
- Serial number of equipment:
Seriennummer des Geräts:
Numéro de série de l'équipement:
Numero de serie del equipo:
Matricola dell'attrezzatura:
Número de série do equipamento

All

Has been manufactured in conformity with
Wurde hergestellt in Übereinstimmung mit
Est fabriqué conformément
Ha sido fabricado de acuerdo con
E' stata costruita in conformità con
Foi fabricado em conformidade com

Directive/Standards Richtlinie/Standards Directives/Normes Directriz/Los Normas Direttiva/Norme Diretrizes / Normas	No. Nr Numéro No n. N°	Approved body Prüfung durch Organisme agréé Aprobado Collaudato Aprovado
EN ISO Machinery Directive	12100:2010 2006/42/EC:2006	TÜV Registered No. K1508/M06 Test Report – K2510/M06

- Special Provisions/Spezielle Bestimmungen/Dispositions particulières/Provisiones especiales/Disposizioni speciali/disposições especiais: **NONE**
- Representative in the Union: **Patrick Vervier, Stanley Dubuis 17-19, rue Jules Berthonneau-BP 3406 41034 Blois Cedex, France.**
Vertreter in der Union/Représentant dans l'union/Representante en la Union/Rappresentante presso l'Unione/Representante do sindicato

Done at/Ort/Fait à/Dado en/Fatto a/Feito em Stanley Hydraulic Tools, Milwaukie, Oregon USA Date/Datum/le/Fecha/Data 1-5-11

Signature/Unterschrift/Signature/Firma/Firma/Assinatura

Position/Position/Fonction/Cargo/Posizione/Posição Director of Product Development

TABLE OF CONTENTS

SAFETY SYMBOLS.....	4
SAFETY PRECAUTIONS	5
TOOL STICKERS & TAGS	7
PRE-OPERATION	9
OPERATION	11
PROPER USE & CARE OF TOOL BITS	17
WEAR LIMIT DIMENSIONS	21
TROUBLESHOOTING	25
CHARGING THE MAIN ACCUMULATOR	26
CHARGING THE SIDE ACCUMULATOR	27
RECOMMENDED TORQUE VALUES	28
BOLT PATTERNS	29
ACCESSORIES	29
UPPER BUMPER	30
MBX 408, 458, 608 COVER PLATE	31
MBX608 CYLINDER AND LOWER BODY CHANGE IN 2012.....	32
FLOW TEST PROCEDURES	33
SPECIFICATIONS	34
SERIAL NUMBER LOCATIONS	35
POWER CELL ILLUSTRATION	37
TOOL BITS	61

IMPORTANT

To fill out a product warranty validation form, and for information on your warranty, visit www.stanleyinfrastructure.com and select the Company tab > Warranty.

Note: The warranty validation record must be submitted to validate the warranty.

SERVICING: This manual contains safety, operation and routine maintenance instructions. STANLEY recommends that servicing of hydraulic tools, other than routine maintenance, must be performed by an authorized and certified dealer. Please read the following warning.

WARNING







SERIOUS INJURY OR DEATH COULD RESULT FROM THE IMPROPER REPAIR OR SERVICE OF THIS TOOL.

REPAIRS AND / OR SERVICE TO THIS TOOL MUST ONLY BE DONE BY AN AUTHORIZED AND CERTIFIED DEALER.

For the nearest certified dealer, call STANLEY at (800) 972-2647 and ask for a Customer Service Representative.

SAFETY SYMBOLS

Safety symbols and signal words, as shown below, are used to emphasize all operator, maintenance and repair actions which, if not strictly followed, could result in a life-threatening situation, bodily injury or damage to equipment.

	<p>This is the safety alert symbol. It is used to alert you to potential personal injury hazards. Obey all safety messages that follow this symbol to avoid possible injury or death.</p>
	<p>This safety alert and signal word indicates an imminently hazardous situation which, if not avoided, <u>will</u> result in <u>death or serious injury</u>.</p>
	<p>This safety alert and signal word indicates a potentially hazardous situation which, if not avoided, <u>could</u> result in <u>death or serious injury</u>.</p>
	<p>This safety alert and signal word indicates a potentially hazardous situation which, if not avoided, <u>could</u> result in <u>death or serious injury</u>.</p>
	<p>This signal word indicates a potentially hazardous situation which, if not avoided, <u>may</u> result in <u>property damage</u>.</p>
	<p>This signal word indicates a situation which, if not avoided, <u>will</u> result in <u>damage to the equipment</u>.</p>
	<p>This signal word indicates a situation which, if not avoided, <u>may</u> result in <u>damage to the equipment</u>.</p>

Always observe safety symbols. They are included for your safety and for the protection of the tool.

LOCAL SAFETY REGULATIONS

Enter any local safety regulations here. Keep these instructions in an area accessible to the operator and maintenance personnel.

SAFETY PRECAUTIONS

Tool operators and maintenance personnel must comply with the safety precautions given in this manual and on the decals and tags attached to the tool and hose.

These precautions are given for your safety. Review them carefully before operating the tool and before performing general maintenance or repairs.

Supervising personnel or the owner operator should develop additional precautions relating to the specific work area and local safety regulations. Place the added precautions in the space provided in this manual.



GENERAL SAFETY PRECAUTIONS

The Hydraulic Breaker will provide safe and dependable service if operated in accordance with the instructions given in this manual. Read and understand this manual and any decals and tags attached to the breaker before operation. Failure to do so could result in personal injury or equipment damage.

- Operate the breaker in accordance with all laws and regulations which affect you, your equipment and the work site.
- Do not operate the breaker until you have read this manual and thoroughly understand all safety, operation and maintenance instructions.
- The operator must be familiar with all prohibited work areas such as excessive slopes and dangerous terrain conditions.
- Do not operate the breaker until you have read the carrier equipment manual and thoroughly understand all safety, operation and maintenance instructions. The word “carrier”, as used in this manual, means a backhoe or excavator or similar equipment used to operate the breaker.
- Ensure that all maintenance procedures recommended in this manual are completed before using the equipment.
- The operator must not operate the breaker or carrier if any people are within the area where they may be injured by flying debris or movement of the equipment.
- Know the limits of your equipment.
- Establish a training program for all operators to ensure safe operation.
- Do not operate the tool unless thoroughly trained or under the supervision of an instructor.
- Become familiar with the carrier controls before operating the carrier and the breaker.
- When operating the breaker you must use ear protection, eye protection and breathing protection.
- While learning to operate the breaker and carrier, do so at a slow pace. If necessary, set the carrier mode selector to the slow position.
- **Warning:** Use of this tool on certain materials could generate dust potentially containing a variety of hazardous substances such as asbestos, silica or lead. Inhalation of dust containing these or other hazardous substances could result in serious injury, cancer or death. Protect yourself and those around you. Research and understand the materials you are cutting. Follow correct safety procedures and comply with all applicable national, state or provisional health and safety regulations relating to them, including, if appropriate arranging for the safe disposal of the materials by a qualified person. Make sure all controls (levers and pedals) are in the NEUTRAL position before starting the carrier.
- While operating the breaker and carrier, keep hands and feet on the controls at all times.
- Before leaving the carrier, always lower the boom and insure the carrier is stable. Never leave the machine with the engine running. ALWAYS ENGAGE THE PARKING BRAKE.
- Stop the engine before attempting to make any repairs, adjustments or servicing to either the carrier or the breaker.
- Do not operate the tool at oil temperatures above 190°F/88°C. Operation at higher temperatures can damage the internal components of the breaker and carrier and will result in reduced breaker performance.
- Do not operate a damaged, leaking, improperly adjusted or incompletely assembled breaker.
- Do not modify the breaker in any manner.
- Use only tool bits supplied by STANLEY. Use of tool bits supplied by another manufacturer may damage the breaker and will void the warranty.
- To avoid personal injury or equipment damage, all breaker repair, maintenance and service must only be performed by authorized and properly trained personnel.
- If you do not understand how to safely operate your breaker, contact an authorized STANLEY Dealer for

SAFETY PRECAUTIONS

assistance.

- Keep this manual with the breaker.
- Do not operate this equipment if you are taking medication which may affect your mental judgement or physical performance.
- Do not operate this equipment if you are under the influence of drugs or alcohol.
- Exposure to crystalline Silica (sometimes called “silica dust”) as a result of breaking, drilling or hammering of rock, concrete, asphalt or other materials may cause Silicosis (a serious lung disease), silicosis-related illnesses, cancer or death. Respiratory protection is highly recommended when working with materials containing Silica Dust. Always wear a respirator approved for protection against crystalline silica.



! WARNING

Do not operate the breaker unless the following safety instructions have been thoroughly read and understood! Read this manual before installing, operating or maintaining this equipment!

- A flying projectile from the breaker, breaker tool, rock or other material may enter the operator's compartment and cause serious or fatal injury to the operator. Personal protection equipment must be used.
- A flying projectile from the breaker, breaker tool, rock or other material may cause serious or fatal injury to bystanders. Never operate the breaker when bystanders are in the work area.
- On some machines/carriers, the breaker can enter the operator's compartment if it breaks loose and swings toward the operator. Make sure that suitable impact shields are used when operating the breaker with this type of equipment.
- Do not operate the breaker unless all safety decals described in this manual are in place. The decals must be inspected periodically to ensure that all wording is legible. The decals must be replaced if illegible. Replacement decals can be obtained from your authorized STANLEY Distributor.
- When operating the breaker you must use ear protection, eye protection and breathing protection.

TOOL STICKERS & TAGS

Shown below and on the next page are decals and stickers found on the equipment that provide important information. Replace decals and stickers when they are no longer legible. Decals may not be of actual size.

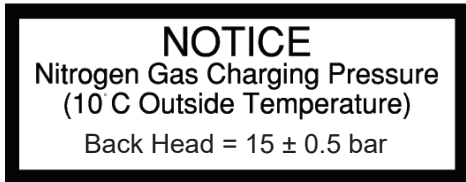

Part Number 72078
Notice: Nitrogen Gas Charging Pressure
(15 Bar) Sticker (MBX 258, 308 & 608 Only)



Part Number 68772
Warning: High Pressure Discharge Sticker



Part Number 47351
Warning: Read Manual, Use Breathing, Hearing, Eye Protection Sticker

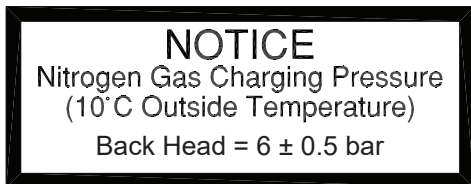

Part Number 68767
Notice: Nitrogen Gas Charging Pressure
(6 Bar) Sticker (MBX 358)

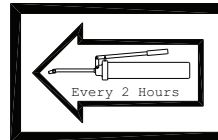

Part Number 68771
Grease Sticker
MBX138 thru MBX608

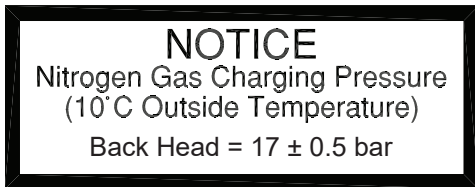

Part Number 68769
Notice: Nitrogen Gas Charging Pressure
(17 Bar) Sticker (MBX138, 208, 408)

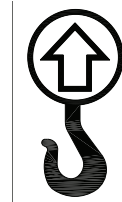

Part Number 68773
Lift Point Sticker

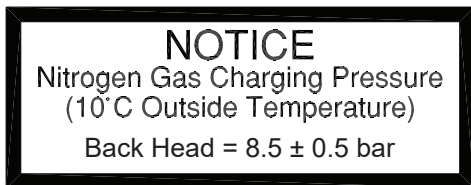

Part Number 68768
Notice: Nitrogen Gas Charging Pressure
(8.5 Bar) Sticker (MBX 458)

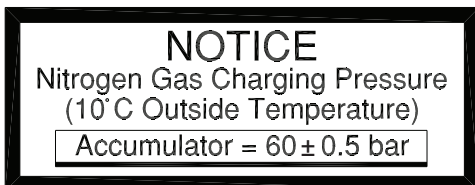

Part Number 68770
Notice: Nitrogen Gas Charging Pressure
(60 Bar) Sticker (Side Accumulator Only) MBX308, 358,
408, 458 and 608.

TOOL STICKERS & TAGS

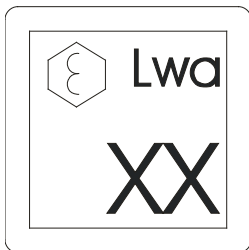

Sound Power Level Sticker

- P/N 72096 – 115 dBA MBX208
- P/N 72097 – 116 dBA MBX138
- P/N 72098 – 120 dBA MBX258, 308, 358
- P/N 72259 – 124 dBA MBX408
- P/N 72260 – 125 dBA MBX458 608



CE Specification Plate

- P/N 74879 – MBX138
- P/N 74880 – MBX208
- P/N 74881 – MBX258
- P/N 74882 – MBX308
- P/N 74883 – MBX358
- P/N 74884 – MBX408
- P/N 74885 – MBX458
- P/N 74886 – MBX608

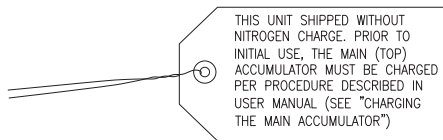

MBX Tag (Accumulator Charge)
P/N 76767

MBXXXX

Model Number Sticker

- P/N 72082 – MBX138
- P/N 72083 – MBX208
- P/N 72084 – MBX258
- P/N 72085 – MBX308
- P/N 72086 – MBX358
- P/N 72087 – MBX408
- P/N 72088 – MBX458
- P/N 72092 – MBX608

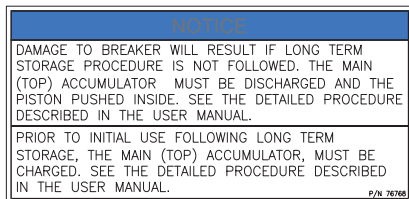

MBX Tag (Long Term Storage)
P/N 76768

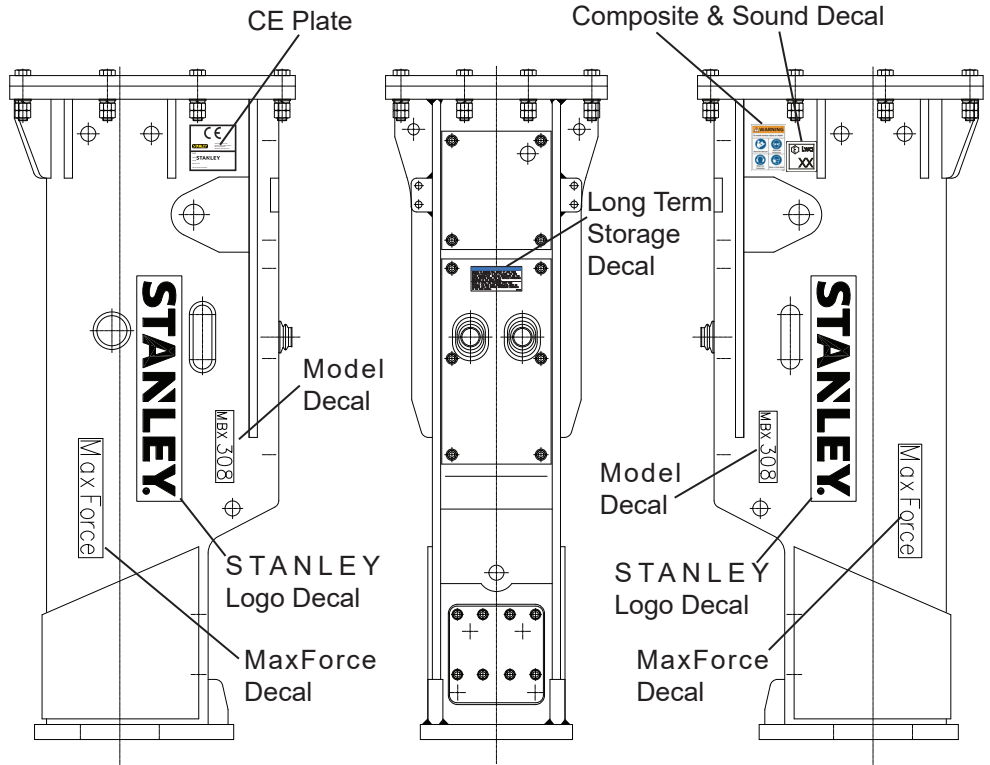

Decal Locations and orientation

STANLEY®

STANLEY Logo Sticker

- P/N 74873 – MBX138, 208
- P/N 74874 – MBX258, 308, 358, 408, 458
- P/N 74875 – MBX608

MAXFORCE

Max Force Logo Sticker

- P/N 74876 – MBX138, 208
- P/N 74877 – MBX258, 308, 358, 408, 458
- P/N 74878 – MBX608

Note: Decals shown are not of actual size

PRE-OPERATION

PRE-INSTALLATION INSTRUCTIONS

EXCAVATOR SIZE

Contact STANLEY to determine correct excavator size. See the "SPECIFICATIONS" section of this manual for hydraulic flow and pressure requirements.

NOTICE

If hydraulic pressure, hydraulic back-pressure, hydraulic flow or excavator weight class are exceeded, the tool warranty is void.

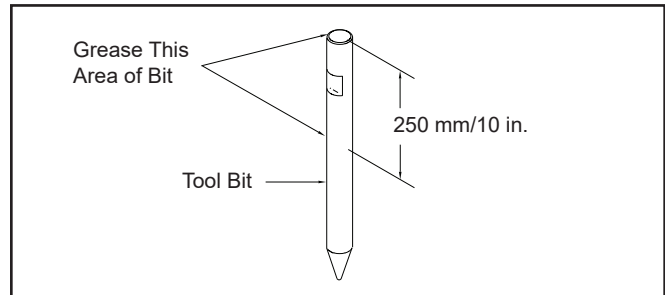

Figure 1. Greasing the Tool Bit Before Installation

EXISTING EQUIPMENT HYDRAULICS

Using existing equipment hydraulic auxiliary systems for operating hydraulic tools could cause problems for the hydraulic tool and the hydraulic system if not set up properly. Do not plug into the hydraulic system without confirming pressure and flow to the hydraulic tool. Spare spool valves, dipper circuits, etc., are examples of easily accessible hydraulic circuits, which could prove to cause problems for hydraulic tool usage.

TEST THE HYDRAULIC SYSTEM

1. Have your STANLEY dealer test the excavator hydraulic system to make sure the system is operating at the manufacturers specified capacity and pressure ratings.
2. Be sure the fluid in the hydraulic system is clean.
3. Check the hydraulic filter. Replace the filter if dirty or deteriorated.
4. Have your STANLEY dealer test the circuit to which the breaker will be connected to make sure that the circuit is supplying the specified flow and pressure rating for the breaker. See the SPECIFICATIONS section of this manual.

PREPARATION FOR OPERATION

NITROGEN CHARGE

The breaker has been properly charged with nitrogen at the factory and is ready to use (see pages 26 and 27) for charging information.

TOOL BIT LUBRICATION

Grease the top 250 mm/10 inches of the breaker tool bit before installing. During operation, the tool can be greased through the grease fitting. Grease as required. **Make sure the tool bit is against the tool stop by placing the tool bit against the ground and then putting down pressure on the breaker. SEE THE ILLUSTRATION BELOW AND ON THE FOLLOWING PAGE.**

NOTICE

Greasing the tool bit without down pressure on the tool will result in grease filling the space between the piston and the tool bit. When the breaker is next activated, the piston will strike the grease at a speed that will cause the grease to apply great force against the seals and grease zerk resulting in damage to these components.

IMPORTANT

COUPLERS

STANLEY highly recommends **not** to use couplers with the large mounted (MBX) series breakers (**Hard plumb only**). The shock from these large mounted breakers can cause the couplers to shake apart and the broken pieces can enter into the breaker causing major damage.

PRE-OPERATION

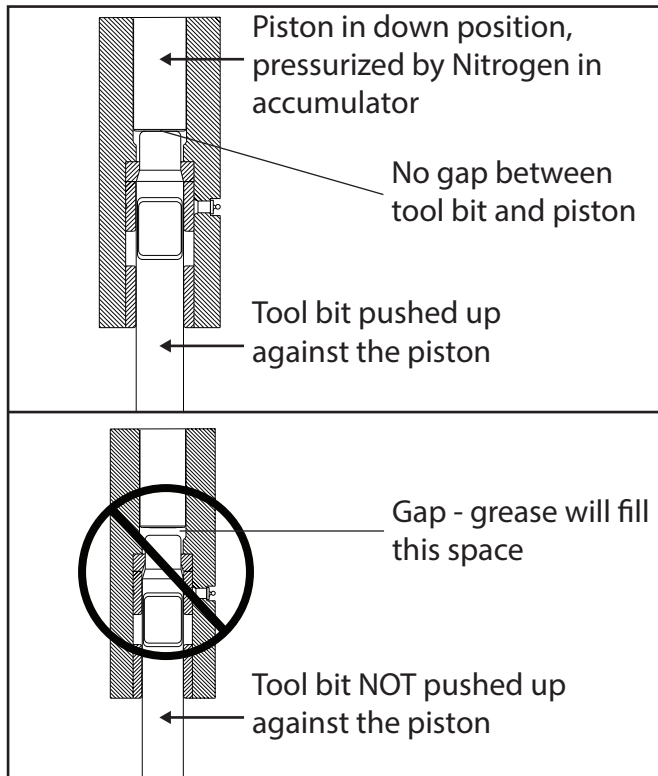

Figure 2.

SECURING THE TOOL

1. Lay the breaker in a horizontal position to install the tool bit. Remove the tool pin retainer plate and the tool retainer plugs, see Figure 3 below.

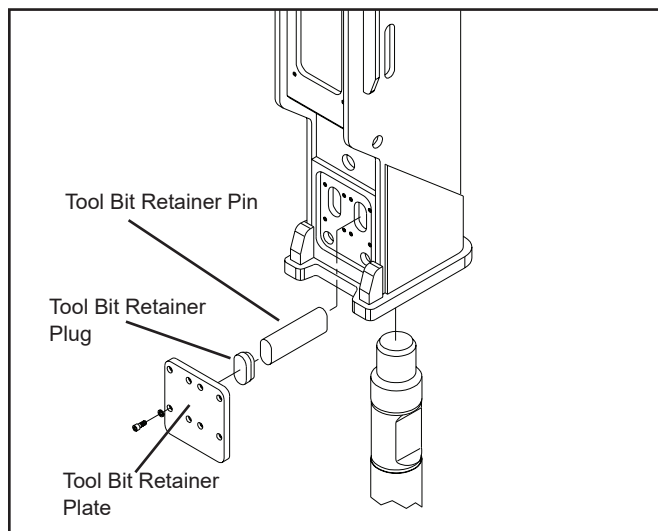

Figure 3.

2. Using a punch and hammer, drive out the tool retainer pins.

WARNING

Flying debris may be caused by striking the rod pins with a punch or hammer. Wear eye protection when installing or removing the rod pins. Failure to wear eye protection may result in eye injury.

3. Grease the top area of the tool bit as shown in the illustration.
4. Install the tool bit making sure the notches are aligned with the lower body tool retainer pin holes.
5. Install the tool retainer pins, tool retainer plugs and retainer plate.

LOW-TEMPERATURE/WARM-UP PROCEDURE

1. After starting the excavator, warm-up the hydraulic system at engine idle until hydraulic lines are warm to the touch.
2. With the excavator at idle and the breaker suspended in the air or with minimal down pressure, turn on the breaker to gradually warm up its internal components.
3. When the hydraulic system and breaker are warm, proceed with operation. See the OPERATION section of this manual.

LONG TERM STORAGE

Use the following procedure if storage of the breaker is expected to be more than 3 - 6 months.

NOTICE

The piston protrudes out the bottom of the cylinder when not in use, although it is inside the lower body it will still be exposed to the elements and can rust, damaging internal components and seals when put back into service. It is very important to protect this exposed surface while the tool is in storage.

Remove the tool bit and discharge the nitrogen gas from the upper accumulator. Push the piston inside the cylinder as far as possible where it will be protected from the elements. Grease or anti corrosion oil spray the lower end of any remaining exposed piston thoroughly. **Failure to do this will result in damage to the tool.** Also thoroughly coat the tool bit, tool stop, retaining pins and lower bushing with grease.

If hoses are attached to the breaker, install plugs on the

OPERATION

hose ends. If hoses are removed from the breaker, install plugs on the hose ends and install plugs in the breaker "IN" and "OUT" ports.

Store breaker in a dry area under cover if possible. It is best to store the breaker in an area that has a consistent temperature to help avoid water condensation causing rust. Store the breaker in a **horizontal** position. **Do not** store the breaker vertical as the piston can drop down exposing the piston to the elements.

If the breaker has been laid horizontally for more than 6 months, check and/or replace all seals. Check for corrosion of bolts before operation.

PREPARATION FOR USE

Read the section in this manual titled PREPARATION FOR USE before operating a breaker. Failure to follow the preparation instructions can result in severe damage to the breaker and excavator and void the warranties of both.

POSITIONING THE EXCAVATOR

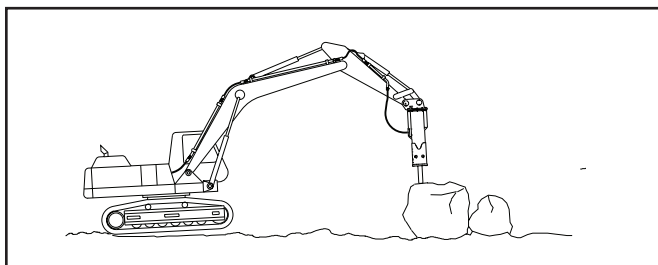

Figure 4. Position the Excavator

With the breaker tool in place on the material to be worked, position the excavator so the dipper is at approximately 45° and the breaker is almost vertical. The tracks of the excavator should be in line with booms and the breaker.

POSITIONING THE BREAKER TOOL ON THE WORK MATERIAL

Position the tool bit near the edge of the work material, not in the center or far from the edge. Position the tool 6-18 inches (depending on the material) from the edge. Breaking off smaller pieces of rock or concrete usually accomplishes more than trying to break larger pieces.

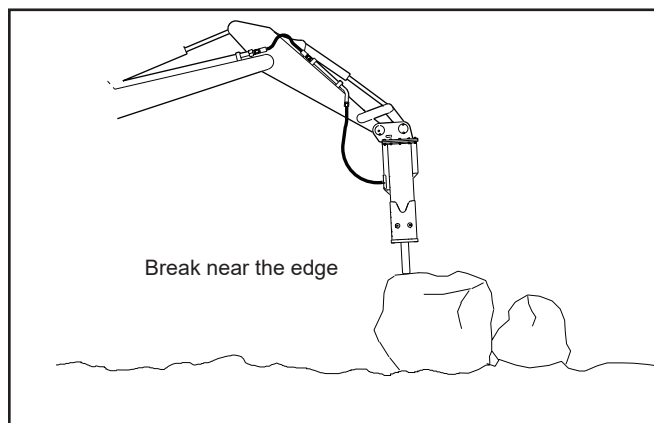

Figure 5. Position the Breaker

On flat material or rock, the breaker should be vertical or "curled" back slightly to direct the impact force downward and toward the backhoe. This directs the force back toward the edge of the work material. If the tool is positioned in the center of the work, or too far from the edge, the energy will be absorbed into the material without cracking it. Do not run the breaker longer than 15-20 seconds. If breakout does not occur within this time, move the breaker to another position.

On flat material such as concrete runways, starting to break in the middle of the material may cause vibrations to be transmitted throughout the breaker and excavator because the material has no place to break to. Always try to start at a point which will permit the material to break out.

MAINTAIN DOWN PRESSURE

Maintaining hard contact with the surface of the material to be broken in addition to maintaining adequate "down force" is very important. Always keep "down pressure" or "down force" on the point of the breaker by lifting the wheels, tracks, or stabilizers slightly above the ground. This method takes the "slack" out of the bracket and boom pivots, and reduces the impact on the pivots in the boom.

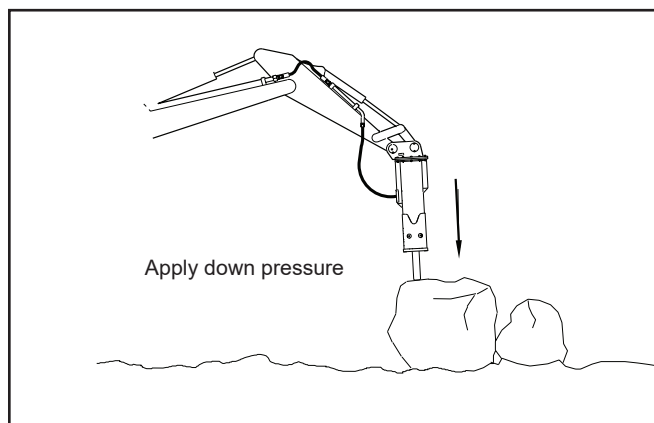

Figure 6. Maintain Down Pressure

OPERATION

The operator needs to be constantly aware of the amount of down pressure being applied and be able to adjust it if necessary. Not enough down pressure results in low production and accelerates wear and tear on the equipment. Too much down pressure may cause the breaker housing to violently crash into the broken material when "break-through" occurs.

In any breaking job, the operator should make every effort to "follow" the breaker with "down-pressure" as the machine breaks farther into the material. The breaker should be stopped as soon as "break-through" occurs or if it is apparent that good solid blows are not occurring.

BREAKING

The operator should note the sound of the blow when the breaker is running. With experience, the operator will be able to tell the difference between a good solid blow and a hollow sounding blow. A hollow blow means that solid blows are not occurring and the breaker should be repositioned.

Continuous tool penetration usually does not do much good. If the material does not break with 3 to 4 inches of tool penetration, it usually won't break with full penetration. The time used for additional penetration could be better used to strike blows in another place.

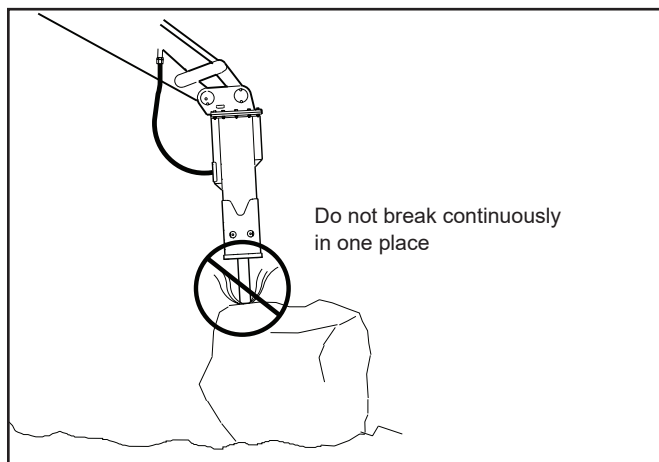

Figure 7. Breaking

NOTICE

Continuous breaking in the same area for lengthy periods will create excessive temperatures at the tip of the tool bit resulting in loss of temper (hardness) of the bit and causing mushrooming of the tip of the bit, and may lead to failure of the bit.

Many materials do not respond well to continued hammering in one place. The breaker tool should be repositioned on the work each time the tool penetrates but does not crack the material.

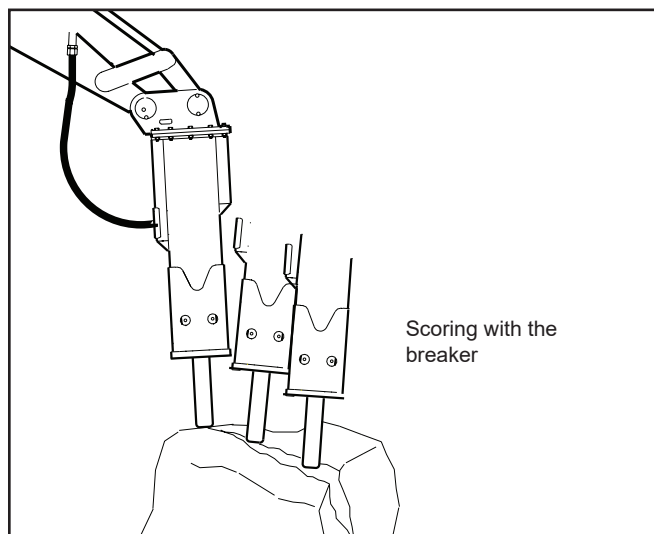

Figure 8. Scoring with Breaker

Use a "scoring" method of breaking when cracking the material becomes difficult. This technique involves striking the rock or concrete at several places along a line where you want the crack to occur. Most materials break sooner when struck several places along a line than when struck repeatedly in one location. On each line, the breaker tool should be continually repositioned. Practice determines the best length of time to stay in one spot (15-20 seconds) and how far to move the breaker tool.

Breaker tool binding can cause erratic breaker operation and premature wear on the tool shank. Breaker tool binding is caused by failure to direct the down force in the direction of the tool bit.

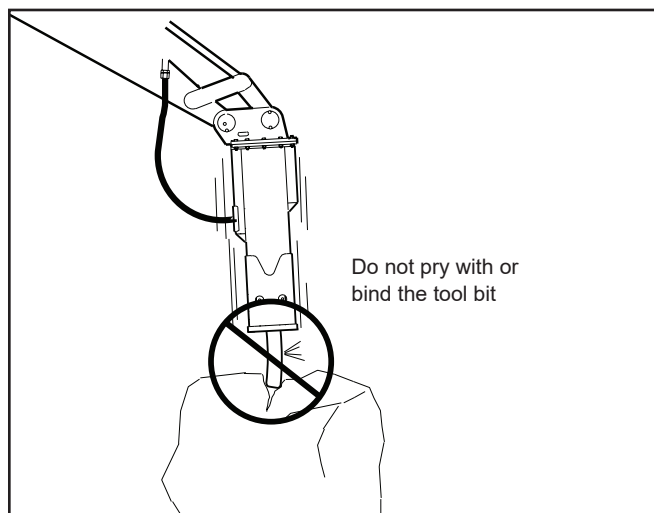

Figure 9. Breaker Binding

OPERATION

Excessive side force cocks the tool in its bore, pre-vents proper movement and causes premature tool shank and bushing wear. Since the breaker tool bit must be pushed up into the breaker to operate, a binding tool prevents the breaker from operating correctly. Binding also causes the tool bit and tool bushings to seize and often results in breakage of one or more breaker components. Always direct the down pressure force in a line toward the point of tool contact with the work.

NOTICE

DO NOT pry with the tool bit and breaker.
Prying will damage the tool bit and associated breaker components.

Moving rocks with the tool bit is another method of binding the tool bit. This practice should be avoided as it may cause tool bit failure.

Rebar reinforced concrete introduces the problem of concrete chunks being held together by the rebar after the concrete has been broken. The best approach to this problem is to use a chisel point tool which permits cutting the rebar with the breaker. Another method is to periodically cut the rebar with an oxyacetylene torch.

OBLIQUE WORK IMPORTANT

Do not use the breaker in a continuous oblique (slanting angle) position (See below). This will cause misaligned hitting of the tool bit and piston resulting in damage to the piston (scratching and eventual cracking) and will also cause the lower bushing to crack. Use breaker in an upright position.

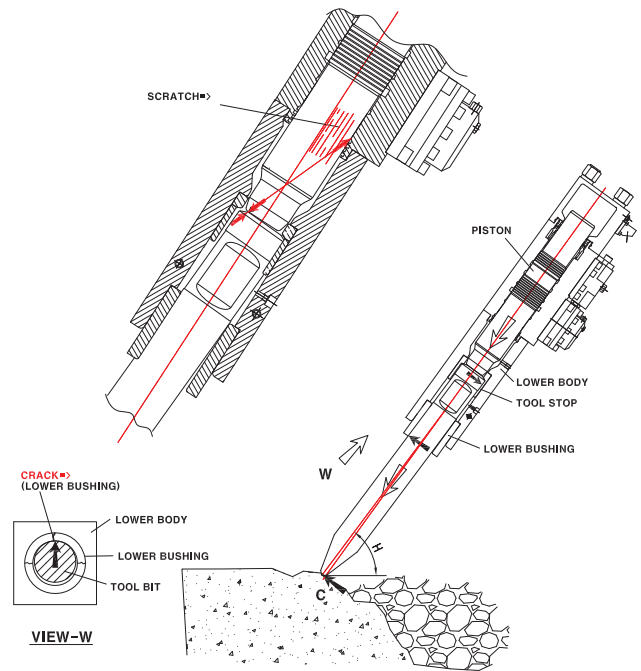

BLANK FIRING

To understand “Blank Firing”,

The operator needs to be aware that if the tool bit is not pressed against the work surface the tool bit will drop down in the lower body cavity far enough so that the piston cannot strike it. Blank firing occurs whenever the breaker is operating and the piston is not able to strike the tool bit solidly or not strike the tool bit at all. Blank Firing accelerates wear and tear on breaker and excavator components and may result in failure of one or more components. Excessive blank firing may be considered equipment abuse and may result in voiding warranties.

Break-through or difficult surface contact results in blank firing when the material being broken fractures and the tool bit is no longer in “hard contact” with the material but is still pushed high enough in the lower body cavity so that the piston can strike it. In this condition, the piston strikes the tool bit and the tool bit, in turn, is driven against the retaining pins because it is not in sufficient contact with the material to be broken. The energy is absorbed by the retaining pins, other breaker components, and the excavator boom components. Blank firing of this type can be experienced in trench work where obtaining striking contact with the work surface is difficult or the wrong tool bit is used, or in flat rock work where the operator fails to stop operation of the breaker when slippage, fracturing or material break-through occurs.

Blank firing as a result of operator error occurs when the tool bit is not in contact with the work surface to be broken and

OPERATION

is allowed to drop down in the lower body cavity so that the piston is not able to strike it. Instead, the downward movement of the piston will be stopped by an internal oil cushion located at the bottom of the piston's stroke and the energy of the piston will be absorbed by breaker components and excavator boom components. Blank firing of this type can be experienced when the operator fails to stop operation of the breaker when the material fractures or material break-through occurs, or during re-positioning of the breaker.

While blank firing cannot always be avoided, it can be kept to a minimum by avoiding the above conditions as much as possible.

UNDERWATER USE

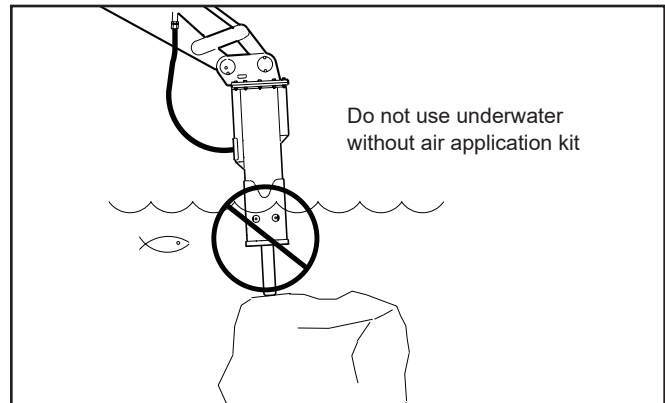

Figure 11. Underwater Use

The breaker is equipped with an underwater port on the side of the breaker. Connect an air line to this port and supply the required air pressure and flow to the breaker when using underwater. The following table shows the air pressure required.

CAUTION

UNDERWATER USE

No part of the breaker may be submerged in water unless an air application kit is used. Underwater usage of the breaker without air application will cause internal damage to the breaker. Consult STANLEY for modifications and specific warranty coverage if you have an underwater requirement.

UNDERWATER KIT P/N-39416

Model	Required Air Amount	Required Air Pressure	Compressor Horsepower-Min	Fitting Location on Exploded View
MBX138	0.5m ³ / min	75-100 psi /5-7 bar	3.7 Kw	Item # 9A
MBX208	0.5m ³ / min	75-100 psi /5-7 bar	3.7 Kw	Item # 9A
MBX258	1.0m ³ / min	75-100 psi /5-7 bar	3.7 Kw	Item # 9A
MBX308	1.0m ³ / min	75-100 psi /5-7 bar	3.7 Kw	Item # 9A
MBX358	1.0m ³ / min	75-100 psi /5-7 bar	3.7 Kw	Item # 71
MBX408	1.0m ³ / min	75-100 psi /5-7 bar	3.7 Kw	Item # 72A
MBX458	1.0m ³ / min	75-100 psi /5-7 bar	3.7 Kw	Item # 72A
MBX608	1.0m ³ / min	75-100 psi /5-7 bar	3.7 Kw	Item # 9A

OPERATION

UNDERWATER KIT P/N-39416

< UNDER WATER OPERATION >
 1) FOR MBX138 ~ MBX608 BREAKER AND MBX15

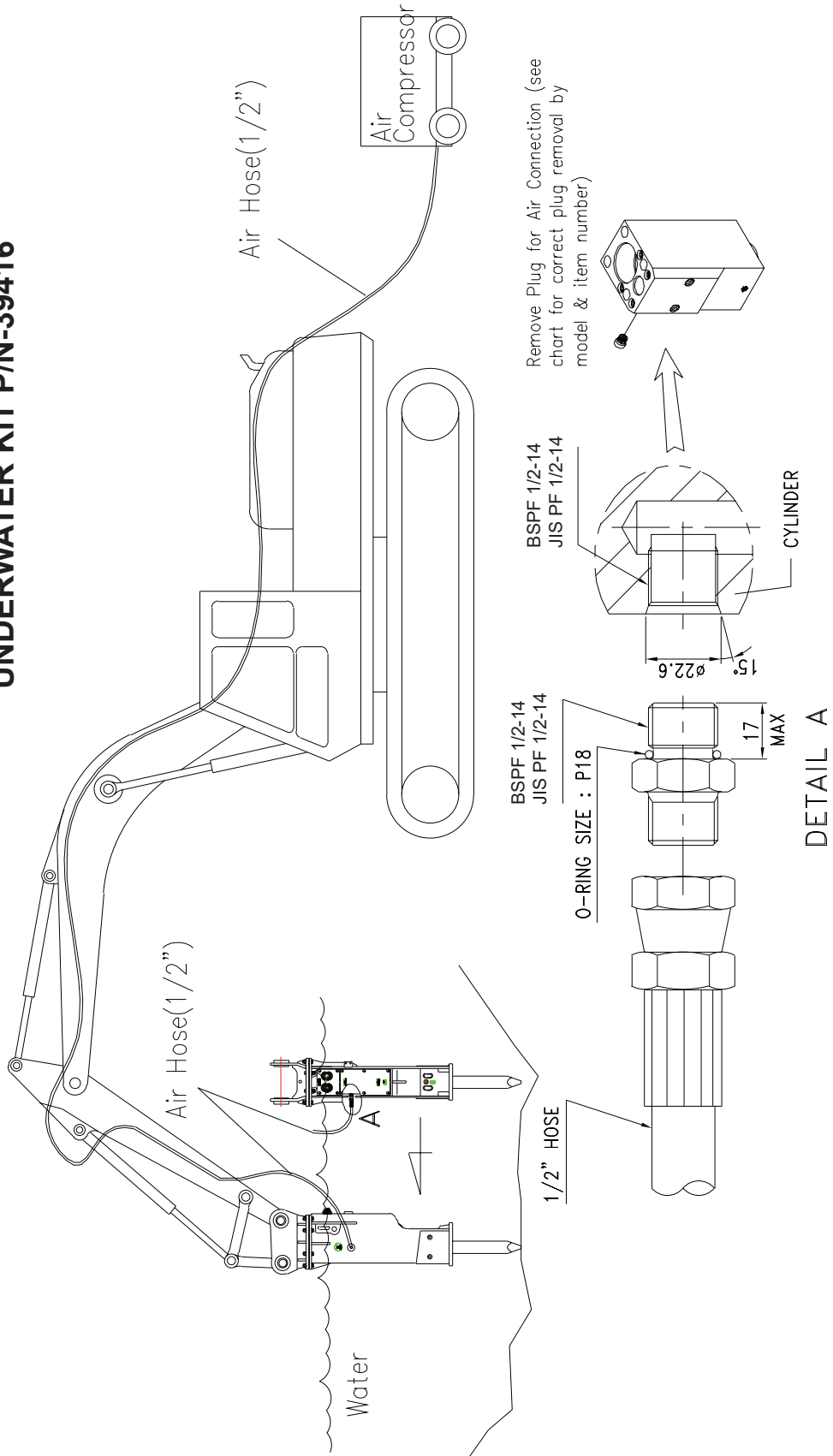

OPERATION

IMPORTANT

DAILY CHECK (MUST BE PERFORMED)

- Check for loose or missing fasteners. Tighten or replace as needed.
- Inspect tool retaining pins and pockets for wear.
- Check for hydraulic leaks at all fittings and hoses. Replace any defective hoses.
- Apply grease to the grease fitting in the lower body each morning. Grease as needed throughout the work day.
- Inspect the lower bushing, tool retainer, tool retainer pins. Reseat or replace if necessary.

TOOL STOP & LOWER BUSHING

Inspect the tool stop and lower bushing for excessive galling and metal pickup on the tool bit. Also check for cracks. If cracks are present, the parts must be replaced.

The extent of wear of the tool stop and lower bushing and the tool bit can be checked by moving the tool bit back and forth and measuring the gap between the tool bit and the lower bushing. If the gap is more than 0.354 in./9 mm the tool stop, lower bushing, and the tool bit should be replaced. A gap in excess of 0.354 in./9 mm will cause damage to the piston. Do not replace the tool bit or the lower bushing individually as this will result in premature wear of the replaced component. It is recommended to replace **all** worn components.

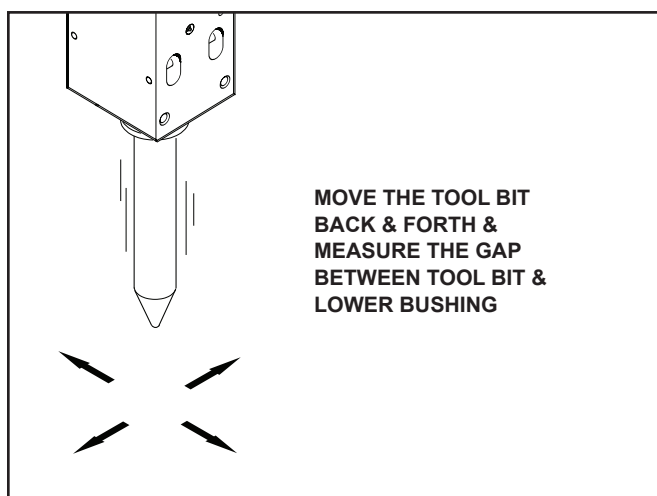
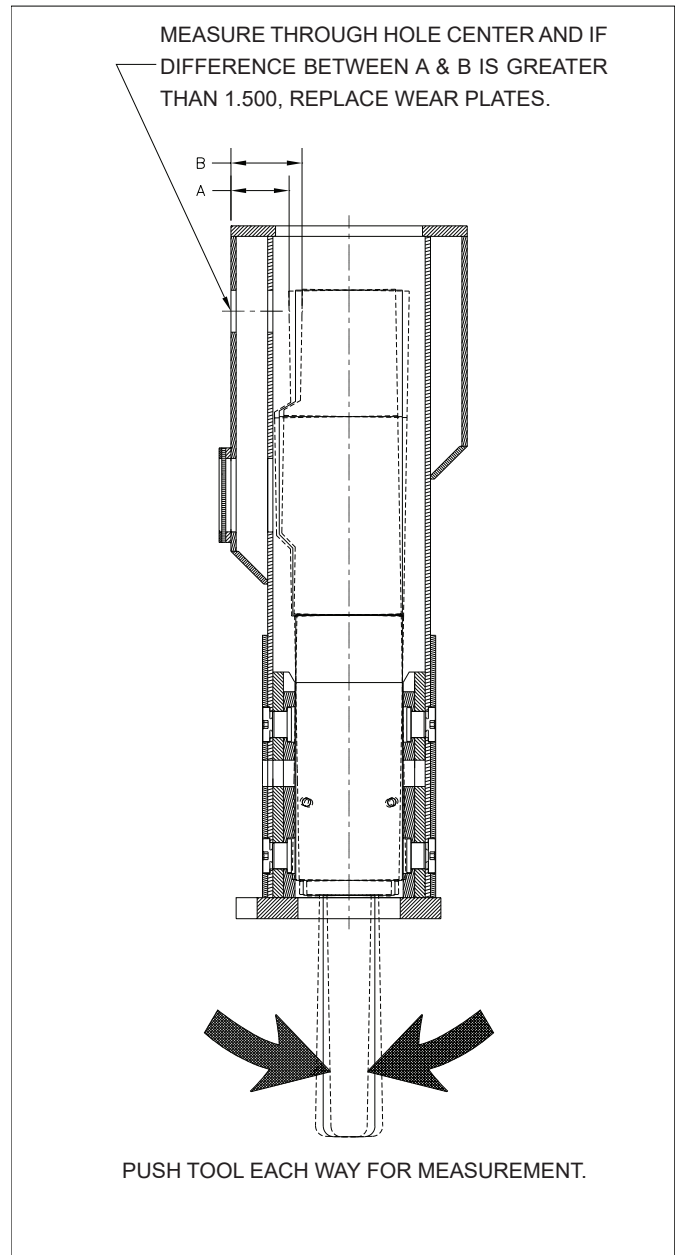

Figure 12. Checking for Wear

PERIODIC MAINTENANCE CHECKS

- Periodically check wear pad clearance by moving the power cell back and forth. Set the breaker on the bit and then use the excavator to move it from side to side as shown in the illustration. If the deflection exceeds 1.5 inches, replace the wear pads.



Tool bits are made and heat treated to specification.

Tool bits are wear parts and are used in the most destructive applications. Even when the hydraulic breaker is used

PROPER USE & CARE OF TOOL BITS

properly and the operator is experienced, a tool bit may become damaged. When a tool bit has been damaged, it is useful to determine the cause immediately in order to prevent the damage from occurring again.

All STANLEY tool bits are machined and hardened for maximum performance. Care must be taken to maintain the tools original condition for optimum productivity and life expectancy. It is not uncommon for an operator who is unfamiliar with using a hammer to break a point. This is part of the learning experience.

Listed below are several methods to determine tool failure and will quickly aid in warranty determination.

TOOL FAILURE NOT COVERED UNDER WARRANTY

BLANK FIRING OR FREE RUNNING

This occurs when the tool is not in proper contact with the work, thus causing the energy produced by the hammer to be concentrated on the tool retainers and the retainer slots on the tool itself. Caution should be used to prevent the hammer from sliding off slanted surfaces or when breaking through thin material.

The illustration below is typical of the kind of breakage that occurs from excessive blank firing.

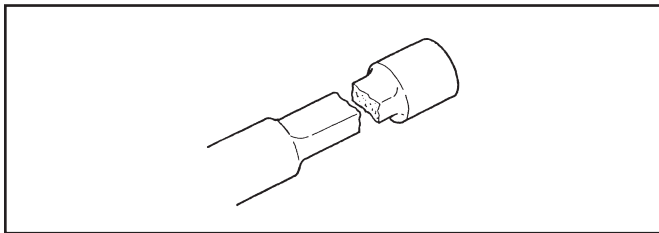

Figure 13. Excessive Blank Firing Breakage

WORN-OUT FRONT BUSHING(S) OR RETAINER PIN(S)

Worn-out front bushings will cause the tool to become misaligned inside the hammer. This misalignment will cause uneven contact between the piston and tool, thus causing stress to concentrate on one particular area of the tool. This can also cause the tool to bind inside the hammer. Call your dealer for acceptable wear allowances.

Worn-out retainer pins will cause uneven loading on the pins themselves, causing failure of the tool or retainer pins. This will also cause excessive wear to the front bushings.

METAL-TO-METAL CONTACT

Extreme caution should be used to avoid scratches or gouges on the surface of the tool. These areas create a stress concentration metal-to-metal contact point, thus weakening the tool.

Another form of metal-to-metal contact is galling, which usually occurs from the lack of lubrication. Special care should be taken to keep the tool shank lubricated every two (2) to three (3) hours.

Steel failures that were caused by surface damage take two main forms. The simplest form is caused by deep scratches on working steel surface. The broken surface has a shell pattern around the starting point of failure, similar to the one in the fatigue failure. The other parts of the broken surface are brittle. These failures work slowly through the steel until it suddenly parts completely.

The second form of failure caused by surface damage occurs when there are deep scratches on working steel surface and there was also excessive bending stress. The broken surface also shows the shell pattern, but the other parts of the broken surface are brittle and usually have a “lip” like that in a stress failure.

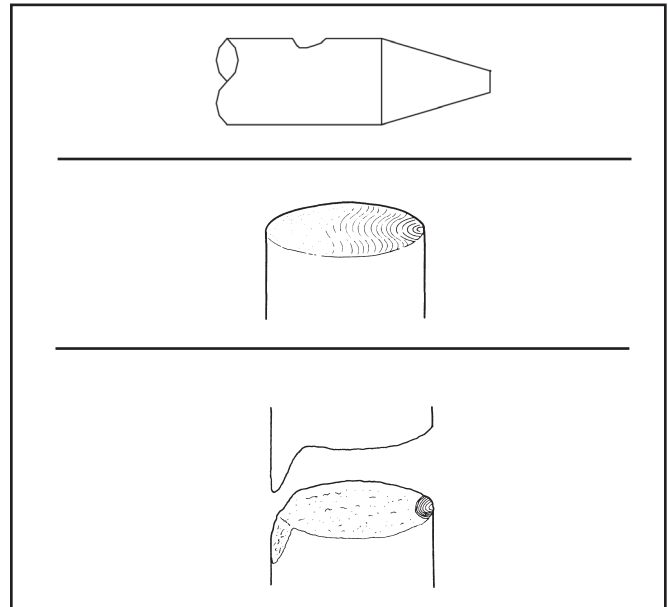

Figure 14. Metal-to-Metal Contact Examples

In its most extreme forms, the combination of surface damage and severe bending can quickly break even the best working steels.

The illustrations below show examples of severe stress breaks.

PROPER USE & CARE OF TOOL BITS

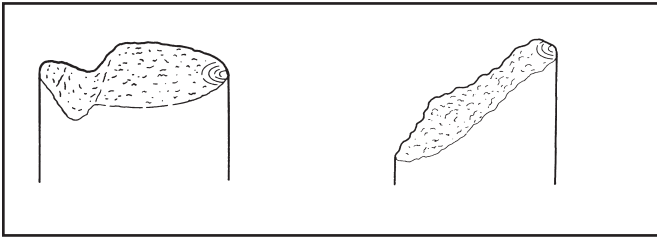

Figure 15. Severe Stress Breaks

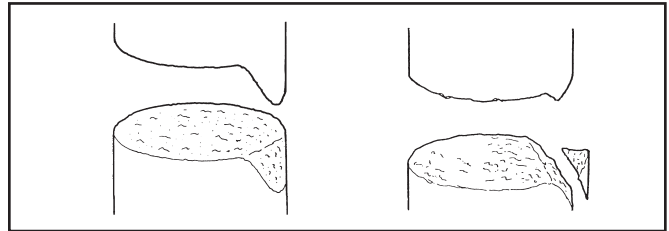

Figure 18. Fatigue Failures

PRYING

This is the most common cause of tool failure. Even when there is no surface damage, the stress from prying can easily break a working steel. This kind of failure generally results from any type of side pressure such as an incorrect breaking angle or from using the tool to reposition material. The tool should not be used as a pivot point when repositioning the carrier. The power generated by the carrier will far exceed the strength of the tool.

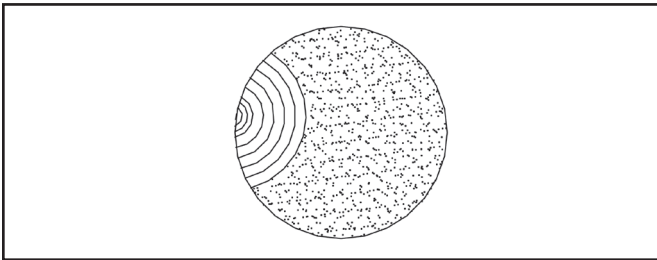

Figure 16. Prying Damage Example

Similar failures can also occur when the steel is used with extreme down pressure and the steel repeatedly slips off the work at an angle, or the material itself moves from under the working steel.

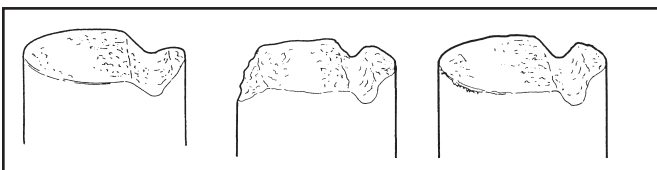

Figure 17. Extreme Down Pressure Breakage

As the next illustration shows, fatigue failures take many forms, but they all exhibit similar features. Generally, the broken surface is brittle and has a "lip" like that in the bending failure, even though, in some cases, the lip has been broken.

CORROSION

Tools should be greased and stored out of the weather. Corrosion tends to accelerate the fatigue fractures of the tool.

MUSHROOMING

Driving the tool into hard material for a long period of time generates an intense heat, indicated by a blue tone just above the point. This will soften the steel and cause the point to fold over, or mushroom, the end of the tool. Avoid hammering in one location for too long. If material does not break after a short period (approximately 15 to 20 seconds), reposition the tool.

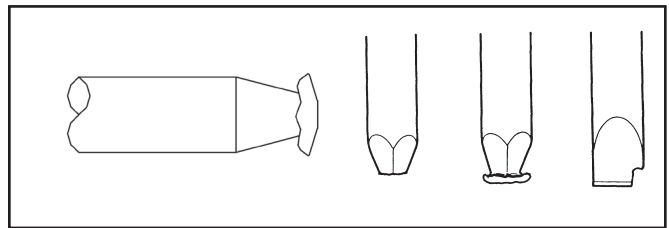

Figure 19. Mushrooming

If the overheated steel is suddenly cooled by being dipped in standing water, the metal will harden and become brittle. These are some examples of failure caused by temper changes occurring on the job.

TOOL FAILURE COVERED UNDER WARRANTY

INTERNAL MATERIAL FLAW

This failure occurs when a foreign material is rolled into the steel during the manufacturing process, causing an imperfection in the internal material grain. The result is an inherent weakness in the tool shank and eventual breakage.

The fatigue failure is started by the defects within the tool bit. The broken surface exhibits a shell pattern around the starting point of failure, like that in the fatigue failure. The other parts of the broken surface are brittle.

PROPER USE & CARE OF TOOL BITS

This is the only kind of tool bit failure that is always covered under warranty.

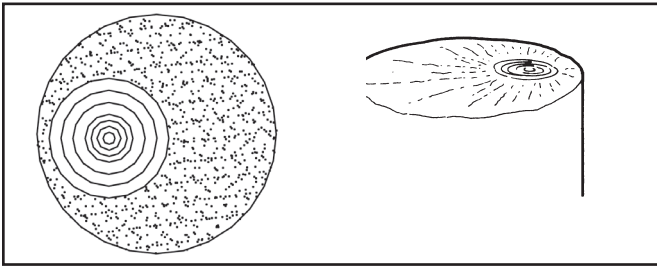

Figure 20. Internal Material Flaw

Working steel failures can be diagnosed by looking at the break itself, and at the place on the steel where the break occurred. Discoloration, like “rainbow” effects or blue bands, is the result of extreme heat.

Look for surface cracks, galling or gouge marks. Breaks that start as surface damage have a “sea shell” pattern, with the damaged spot at the center. A large “sea shell” indicates a slow growing break; a small one indicates one compounded by side stress.

Stress failures start small, and spread into the center of the steel. In a stress failure, the coarser the grain, the greater the stress was, and the more rapid was the failure.

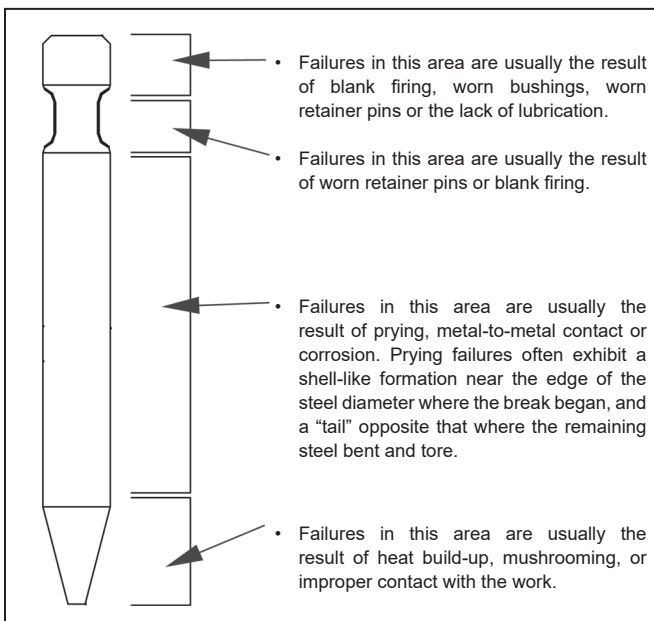

Figure 21. Diagram of Tool Bit Failures

PROPER USE & CARE OF TOOL BITS

STANLEY breakers are available with several different types of tool bits. The most common are the cross cut, moil and conical. Each of these working steels has its own purpose as described below:

To obtain the maximum production from the breaker, it is important to select the proper working steel. Consult your STANLEY representative for assistance in selecting the proper working steel for your application.

CROSS CUT CHISEL



This style of point is used generally for civil engineering work. It is also suitable for splitting and used for breaking flat rocks and concrete. Also used for trench work, where a controlled break is required, and for rock breaking materials with a definite line of cleavage.

MOIL



This moil point, also referred to as “Pyramidal”, is used for hard rocks or reinforced concrete. This bit is mostly used and is generally suitable for splitting. However, it cannot break an object into pieces at a blow as a flat bit does. Further, as it may slip during hammering, hammering must be performed with the point stabilized.

CONICAL

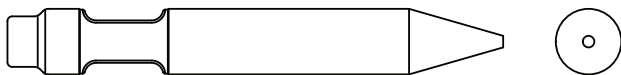

This conical point, also referred to as “Cone”, is used generally for soft, non-abrasive rock or concrete.

BLUNT

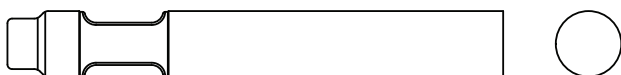

This style of point is used to break softer material and rocks, other than excessively hard rocks. With the bit being flat, locating the bit on an object to be broken is easier and the bit seldom slips during hammering. A flat blunt bit will shatter soft material, such as coal or shale. It is also useful when breaking irregularly shaped material, where its broad tip makes it easier to position.

LINE CUT CHISEL

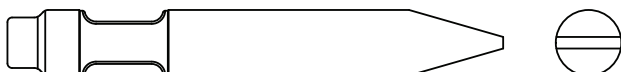

This style of point is used for civil engineering work. It is also suitable for splitting, and used for breaking flat rocks and concrete. Also used for trench work, where a controlled break is required, and for rock breaking materials with a definite line of cleavage.

WEAR LIMIT DIMENSIONS

INSPECTION / REPLACEMENT OF TOOL BIT/LOWER BUSHING

Model	Wear Limit
MBX138	5 mm / 0.196 in.
MBX208, MBX258, MBX308	6 mm / 0.236 in.
MBX358, MBX408, MBX458	6 mm / 0.236 in.
MBX608	7 mm / 0.275 in.

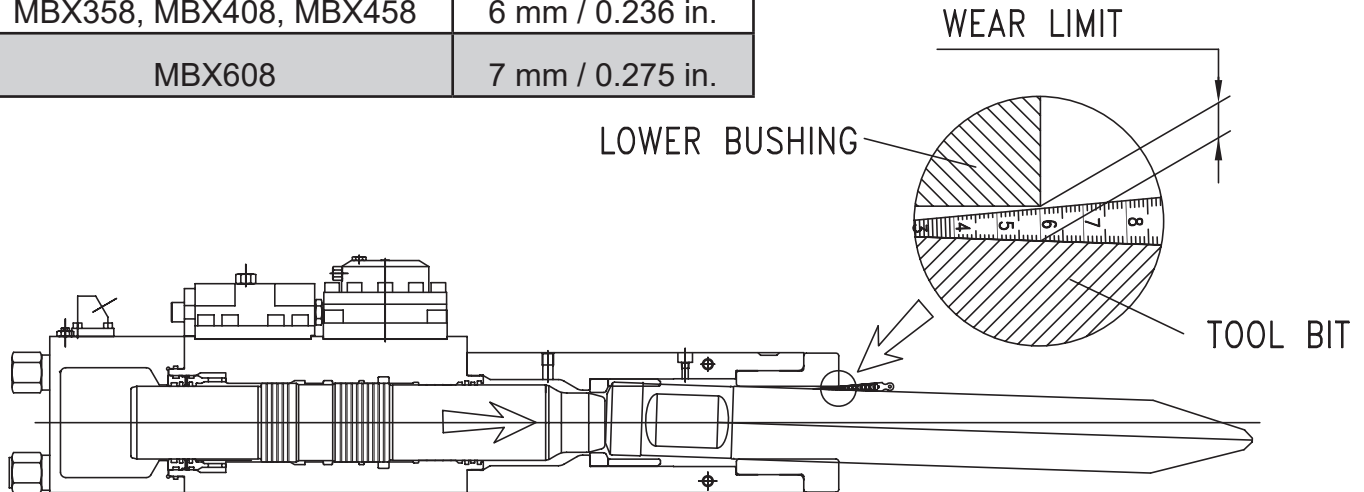

LOWER BUSHING

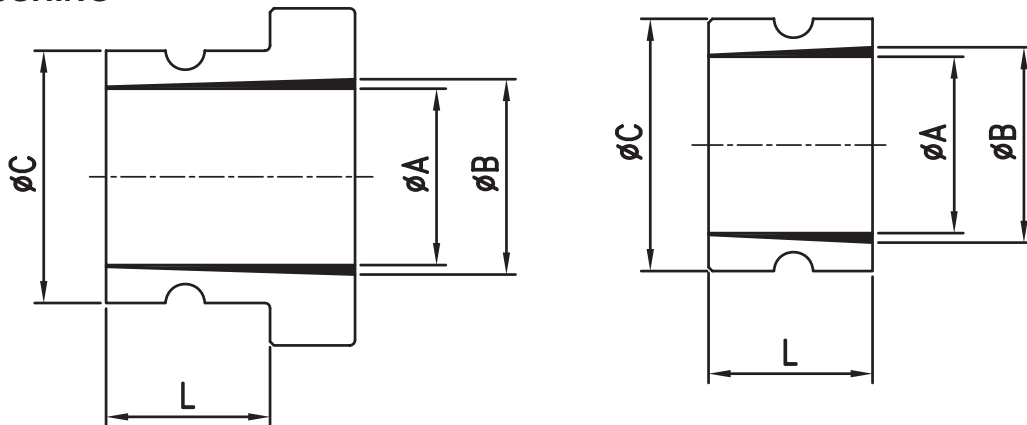

Model	$\varnothing A$ New Part	$\varnothing B$ Wear Limit	$\varnothing C$	L
MBX138	100 mm / 3.937 in	105 mm / 4.133 in	143 mm / 5.629 in	110 mm / 4.330 in
MBX208	125 mm / 4.921 in	131 mm / 5.157 in	178 mm / 7.007 in	115 mm / 4.527 in
MBX258	135 mm / 5.314 in	141 mm / 5.551 in	193 mm / 7.598 in	125 mm / 4.921 in
MBX308	140 mm / 5.511 in	146 mm / 5.748 in	200 mm / 7.874 in	110 mm / 4.330 in
MBX358	150 mm / 5.905 in	156 mm / 6.141 in	210 mm / 8.267 in	150 mm / 5.905 in
MBX408	155 mm / 6.102 in	161 mm / 6.338 in	210 mm / 8.267 in	130 mm / 5.118 in
MBX458	160 mm / 6.229 in	166 mm / 6.535 in	230 mm / 9.055 in	170 mm / 6.692 in
MBX608	175 mm / 6.889 in	181 mm / 7.125 in	257 mm / 10.118 in	151.5 mm / 5.964 in

WEAR LIMIT DIMENSIONS

TOOL STOP

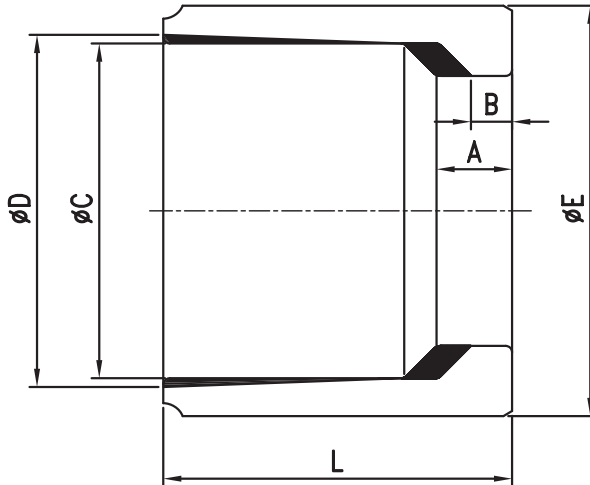

Model	A New Part	B Wear Limit	ØC New Part	ØD Wear Limit	ØE	L
MBX138	17 mm 0.669 in	14 mm 0.551 in	100 mm 3.937 in	105 mm 4.133 in	122 mm 4.803 in	117 mm 4.606 in
MBX208	31 mm 1.220 in	28 mm 1.102 in	125 mm 4.921 in	131 mm 5.157 in	151 mm 5.944 in	151 mm 5.944 in
MBX258	27.2 mm 1.070 in	24.2 mm 0.952 in	135 mm 5.314 in	141 mm 5.551 in	162 mm 6.377 in	131 mm 5.157 in
MBX308	40 mm 1.574 in	37 mm 1.456 in	140 mm 5.511 in	146 mm 5.748 in	170 mm 6.692 in	181 mm 7.125 in
MBX358	35 mm 1.377 in	32 mm 1.259 in	150 mm 5.905 in	156 mm 6.141 in	180 mm 7.086 in	155 mm 6.102 in
MBX408	35 mm 1.377 in	32 mm 1.259 in	155 mm 6.102 in	161 mm 6.338 in	190 mm 7.480 in	143 mm 5.629 in
MBX458	35 mm 1.377 in	32 mm 1.259 in	160 mm 6.299 in	166 mm 6.535 in	192 mm 7.559 in	176 mm 6.929 in
MBX608	53.5 mm 2.106 in	50.5 mm 1.988 in	175 mm 6.889 in	181 mm 7.125 in	214 mm 8.425 in	234 mm 9.212 in

WEAR LIMIT DIMENSIONS

UPPER BUMPER

- MBX138 ~ MBX458

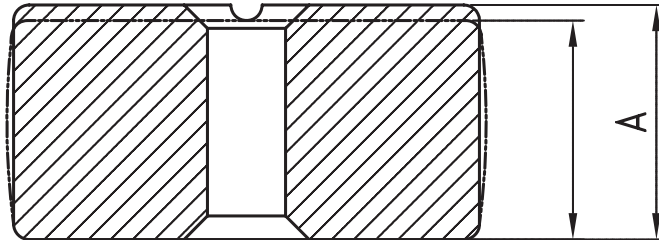

- MBX608

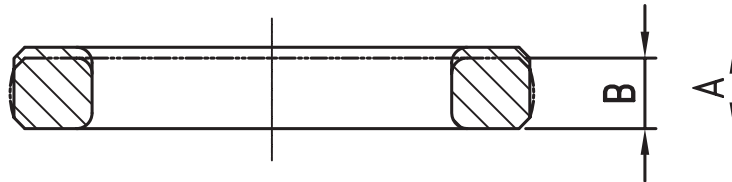

Model	A New Part	B Wear Limit
MBX138	116 mm / 4.566 in	111 mm / 4.370 in
MBX208	116 mm / 4.566 in	111 mm / 4.370 in
MBX258	127 mm / 5.000 in	122 mm / 4.803 in
MBX308	127 mm / 5.000 in	122 mm / 4.803 in
MBX358	142 mm / 5.590 in	137 mm / 6.141 in
MBX408	150 mm / 5.905 in	145 mm / 5.708 in
MBX458	150 mm / 5.905 in	145 mm / 5.708 in
MBX608	52 mm / 2.047 in	49 mm / 1.929 in

WEAR LIMIT DIMENSIONS

TOOL RETAINER PIN

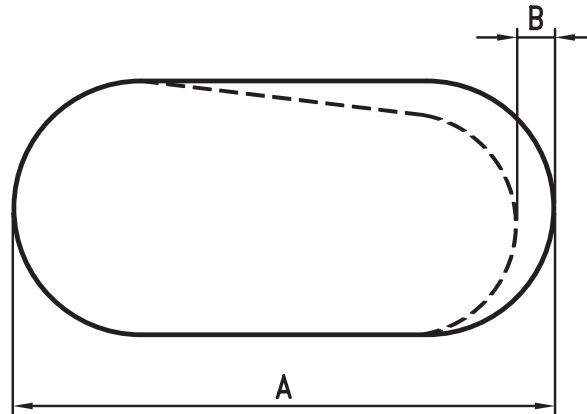

Model	Dimension (A) New Part	Wear Limit Dimension (B)
MBX138	60 mm / 2.362 in	3 mm / 0.118 in
MBX208	76 mm / 2.992 in	3 mm / 0.118 in
MBX258	80 mm / 3.149 in	4 mm / 0.157 in
MBX308	88.5 mm / 3.484 in	4 mm / 0.157 in
MBX358	88.5 mm / 3.484 in	4 mm / 0.157 in
MBX408	99.5 mm / 3.917 in	6 mm / 0.236 in
MBX458	99.5 mm / 3.917 in	6 mm / 0.236 in
MBX608	99.5 mm / 3.917 in	6 mm / 0.236 in

TOOL BIT

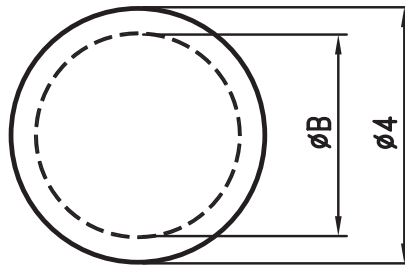

Model	Dimension (A) New Part	Wear Limit Dimension (B)
MBX138	100 mm / 3.937 in	95 mm / 3.740 in
MBX208	125 mm / 4.921 in	120 mm / 4.724 in
MBX258	135 mm / 5.314 in	129 mm / 5.078 in
MBX308	150 mm / 5.905 in	144 mm / 5.669 in
MBX358	150 mm / 5.905 in	144 mm / 5.669 in
MBX408	155 mm / 6.102 in	149 mm / 5.866 in
MBX458	160 mm / 6.299 in	154 mm / 6.062 in
MBX608	175 mm / 6.889 in	169 mm / 6.653 in

TROUBLESHOOTING

If symptoms of poor performance develop, the following chart can be used as a guide to correct the problem.

When diagnosing faults in operation of the breaker, always check that the hydraulic power source is supplying the correct hydraulic flow and pressure to the breaker, as listed in the table. Use a flow meter known to be accurate. Check the flow with the hydraulic oil temperature at least 180 °F/82 °C. An approved test procedure is available in the complete service manual, P/N 41893.

PROBLEM	CAUSE	SOLUTION
Breaker will not fire.	Low hydraulic oil level.	Fill reservoir.
	No flow to breaker.	Have hydraulic circuit tested by authorized dealer/distributor per approved procedure.
	Main relief set too low.	
	Internal damage.	Have unit serviced by authorized dealer/distributor.
Breaker runs slowly.	Low hydraulic flow.	Have hydraulic circuit tested by authorized dealer/distributor per approved procedure.
	Excessive heat build up.	
	Excessive nitrogen pressure.	Have unit serviced by authorized dealer/distributor.
	Internal leakage.	
Breaker runs erratically.	Low or excessive back pressure.	Have carrier serviced by authorized dealer/distributor.
	Damaged switch or connection.	
	Main relief set too low.	
	Internal damage.	Have unit serviced by authorized dealer/distributor.
	Tool binding.	
	Low hydraulic oil level.	
Breaker runs but at reduced power.	Low accumulator charge.	Have unit serviced by authorized dealer/distributor.
	Excessive back pressure.	
	Main relief set too low.	
Breaker leaks oil around tool bit and tool bushing.	Lower seals failed.	Have unit serviced by authorized dealer/distributor.
Hydraulic system overheats.	Main relief set too low.	Have carrier serviced by authorized dealer/distributor.
	Insufficient cooling capability in hydraulic circuit.	
	Line/hose size too small.	
	Excessive back pressure.	

CHARGING THE MAIN ACCUMULATOR

The tools required to charge the main accumulator are shown below. The 33464 adapter and 33300 adapter assembly can be obtained individually or in a kit (P/N 33465). Note that the adapter and adapter assembly are designed to be used with the 505232 charge hose assembly and the 28257 accumulator tester which are used with other STANLEY breakers. When charging the breaker, make sure the tools and charge valve are clean. Dirt can contaminate the charge valve and cause leakage.

1. Remove the protective plug from the accumulator charge valve.
2. Screw the adapter assembly (P/N 33300) onto the tester (P/N 28257) and tighten it.
3. Hold the chuck end of the tester and turn the gauge fully counter clockwise to ensure the plunger inside the chuck is completely retracted.
4. Screw the tester into the breaker charge valve by turning the chuck. Do not use the gauge for turning as this will advance the plunger in the chuck. Tighten the chuck lightly against the breaker charge valve.
5. Turn the gauge clockwise to advance the plunger until a pressure is indicated on the gauge. Do not overtighten.

6. If the pressure is correct, unscrew the gauge to retract the plunger. Then, loosen and remove the tester from the charge valve. If the pressure is not correct, proceed to Step 7.

Note: When disengaging the tester a "POP" of nitrogen is normal.

7. Connect the charge hose assembly to the charging valve on the tester. Make sure the valve on the charge hose assembly is closed. Open the valve on the nitrogen bottle.
8. Very slowly open the valve on the charge hose assembly and slowly meter the nitrogen into the breaker charge valve until the tester reads the correct charge pressure.
9. When the correct pressure is obtained, close the valve on the charge hose assembly and on the nitrogen bottle. Unscrew the gauge to retract the plunger. Loosen and remove the tester from the charge valve. Before replacing the protective plug, inspect the plug O-ring. If damaged or deformed, replace the plug. Apply Loctite™ 242 to plug and cap.

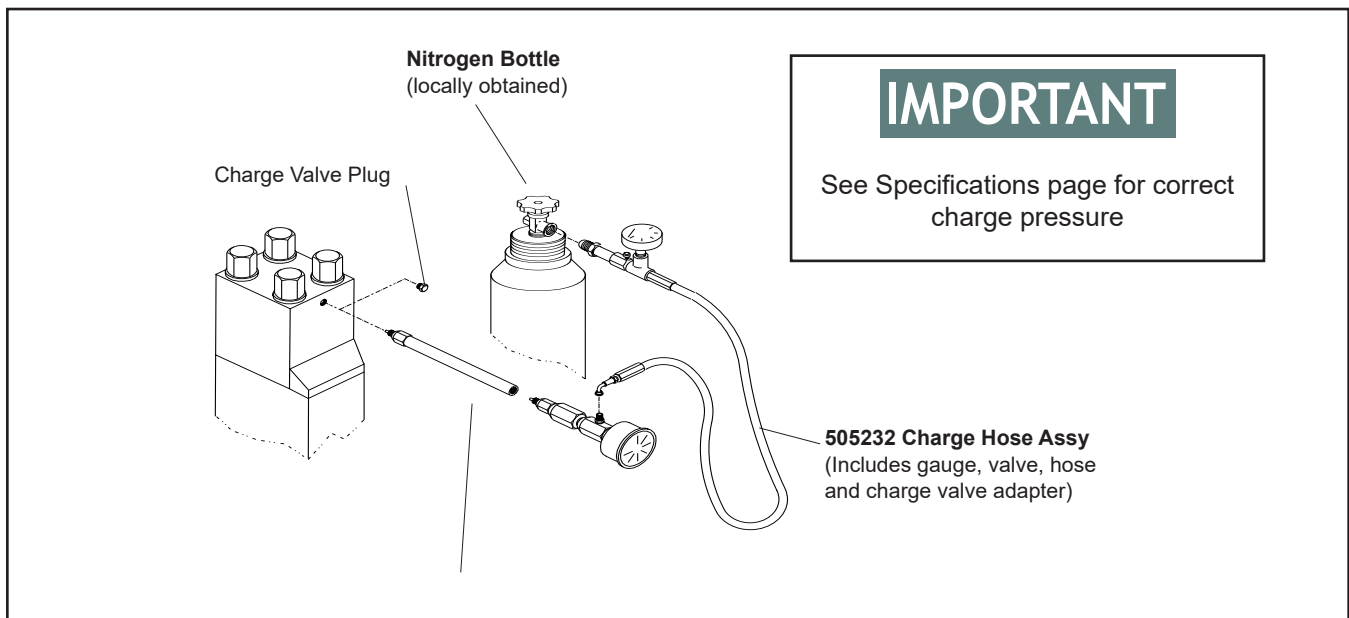

Figure 22. Charging the Main Accumulator

CHARGING THE SIDE ACCUMULATOR

The tools required to charge the side accumulator are shown below. The 33464 adapter and 33300 adapter assembly can be obtained individually or in a kit (P/N 33465). Note that the adapter and adapter assembly are designed to be used with the 505232 charge hose assembly and the 28257 accumulator tester which are used with other STANLEY breakers. When charging the breaker, make sure the tools and charge valve are clean. Dirt can contaminate the charge valve and cause leakage.

1. Remove the protective plug from the accumulator cover.
2. Screw the adapter assembly (P/N 33464) onto the tester (P/N 28257) and tighten it.
3. Hold the chuck end of the tester and turn the gauge fully clockwise until the gauge stops turning. Do not tighten.
4. Screw the tester into the threaded hole, in place of the removed protective plug, by turning the chuck. Do not use the gauge for turning. Tighten the chuck lightly to ensure a good seal.
5. Remove the cap and then turn the charge valve 1 to 2 turns counter clockwise until a pressure is indicated on the gauge.
6. If the pressure is correct, turn the charge valve clockwise until it stops and then tighten slightly. Unscrew the tester and reinstall the plug and cap. If the pressure is not correct, proceed to Step 7.
7. Connect the charge hose assembly to the charging valve on the tester. Make sure the valve on the charge hose assembly is closed. Open the valve on the nitrogen bottle.
8. Very slowly open the valve on the charge hose assembly and slowly meter the nitrogen into the breaker charge valve until the tester reads the correct charge pressure.
9. When the correct pressure is obtained, close the valve on the charge hose assembly and on the nitrogen bottle. Turn the charge valve clockwise until it stops and then tighten slightly. Unscrew and remove the charge hose assembly. Unscrew and remove the tester. Apply Loctite™ 242 and reinstall the plug and cap.

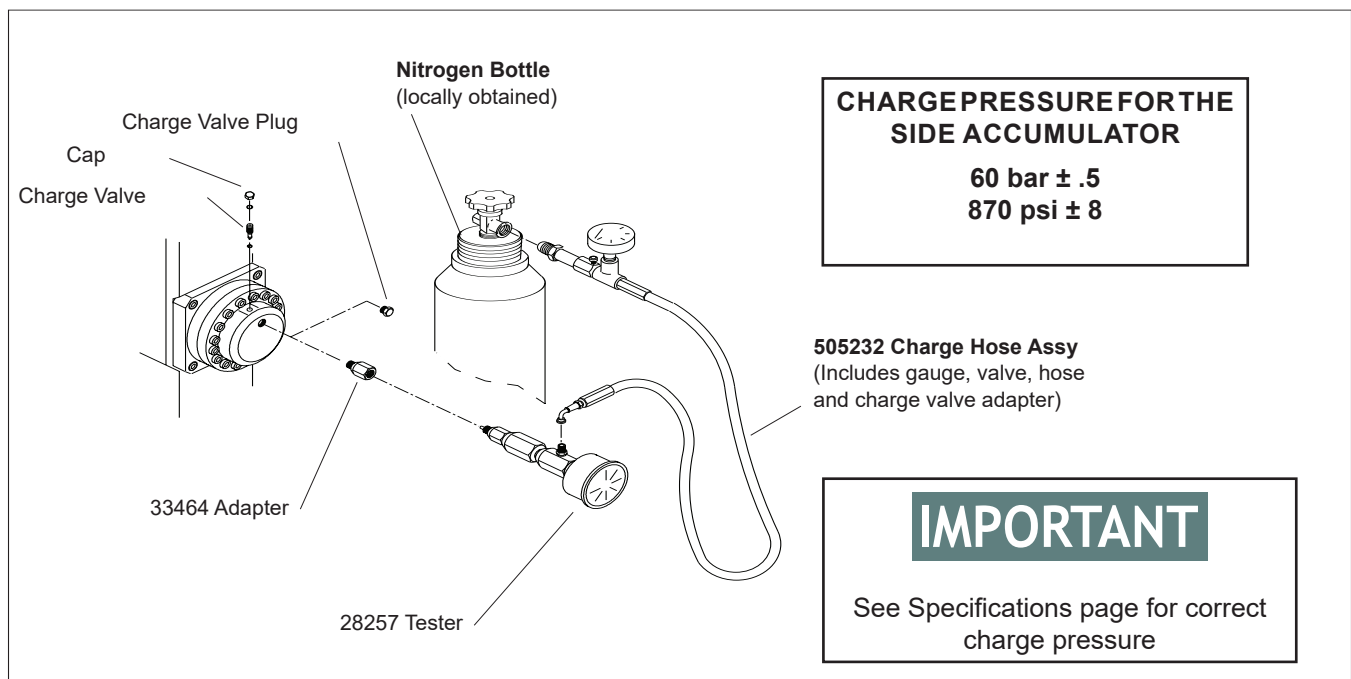
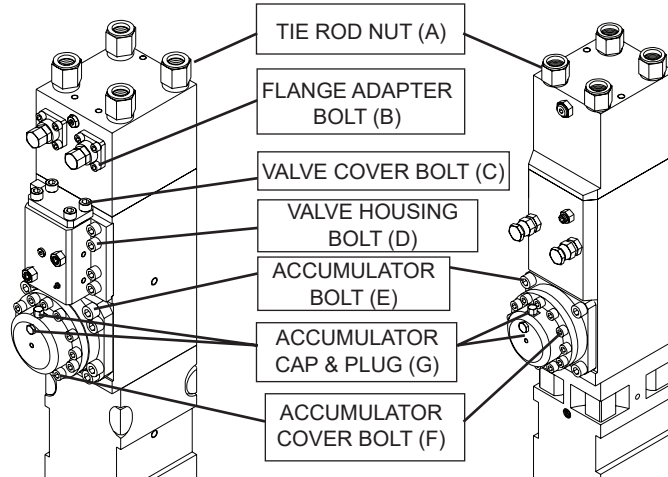
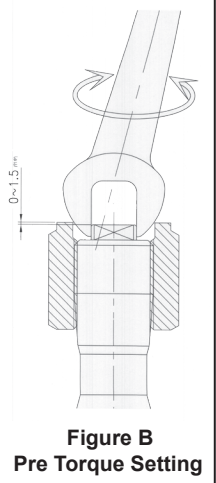

Figure 23. Charging the Side Accumulator

RECOMMENDED TORQUE VALUES



Part Name	MBX138	MBX208	MBX258	MBX308	MBX358	MBX408	MBX458	MBX608	APPLY
A Tie Rod Nut ^{1, 2}	150 kg-m 1085 ft lbs	250 kg-m 1808 ft lbs	280 kg-m 2025 ft lbs	300 kg-m 2170 ft lbs	330 kg-m 2387 ft lbs	420 kg-m 3038 ft lbs	420 kg-m 3038 ft lbs	470 kg-m 3400 ft lbs	Kopr-Kote™
B Flange Adapter Bolt ¹	—	—	—	—	20 kg-m 145 ft lbs	20 kg-m 145 ft lbs	20 kg-m 145 ft lbs	20 kg-m 145 ft lbs	
C Valve Cover Bolt	—	—	—	—	35 kg-m 253 ft lbs	35 kg-m 253 ft lbs	35 kg-m 253 ft lbs		
D Valve Housing Bolt ¹	—	—	—	—	50 kg-m 361 ft lbs	50 kg-m 361 ft lbs	50 kg-m 361 ft lbs		
E Accumulator Bolt ¹	—	—	—	60 kg-m 434 ft lbs	60 kg-m 434 ft lbs	60 kg-m 434 ft lbs	60 kg-m 434 ft lbs	60 kg-m 434 ft lbs	
F Accumulator Cover Bolt ¹	—	—	—	30 kg-m 217 ft lbs	35 kg-m 253 ft lbs	35 kg-m 253 ft lbs	35 kg-m 253 ft lbs	35 kg-m 253 ft lbs	Loctite™ 242
G Accumulator Cap & Plug	—	—	—	10 kg-m 72 ft lbs	10 kg-m 72 ft lbs	10 kg-m 72 ft lbs	10 kg-m 72 ft lbs	10 kg-m 72 ft lbs	



¹ Tighten in a cross pattern
² Pre-torque to 360 ft. Lbs./488 Nm

The torque values for TIE RODS NUTS are to be used with a torque multiplier.

The following procedure is recommended for tie rod torque and may be tightened to the specified torque using the following procedure (see figure A & B).

Recommended Tie Rod Torque Procedure

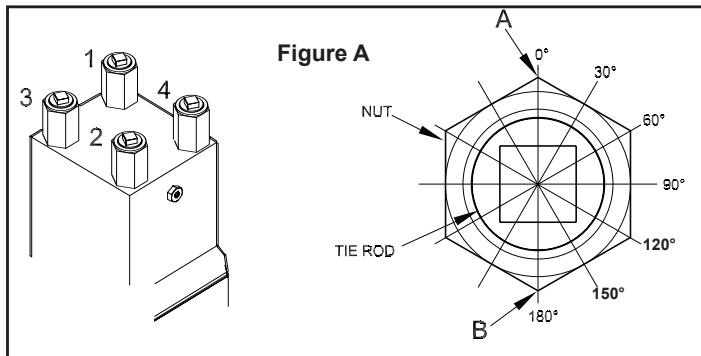

MBX138	MBX208 MBX258 MBX308	MBX358	MBX408 MBX458	MBX608
120°-130°	110°-120°	160°-170°	170°-180°	170°-180°

- Thread tie rod into lower nut by hand until it bottoms out. Install the upper tie rod nut and install all the way down until contacts the top of the main accumulator. Hold the upper nut from turning and, with a wrench, turn just the tie rod until it has a gap, as shown in figure B (0 - 1.5mm / 0 - 0.059 in., top of tie rod flush or just below top of upper tie rod nut).
- Pre-torque the upper tie rod nuts to 360 ft. Lbs. / 488 Nm using a cross pattern as shown in the illustration at the left.
- Using the illustration as a guide, mark a line on each nut and designate it as (A).
- Using the illustration, measure the degrees indicated in the chart for the specific model breaker, from point (A) to point (B) and make a mark near the nut. For example: If working with an MBX208, the degrees listed in figure A for turning the nut to achieve the final torque are listed as 110-120. Make a mark on one point of the nut and designate that point as (A). Measure 110-120 degrees clockwise of point (A) and make a mark next to the nut. Designate that point as (B). Turn the nut clockwise until point (A) and point (B) line up.
- Continue this procedure in a cross pattern on all 4 nuts.

BOLT PATTERNS

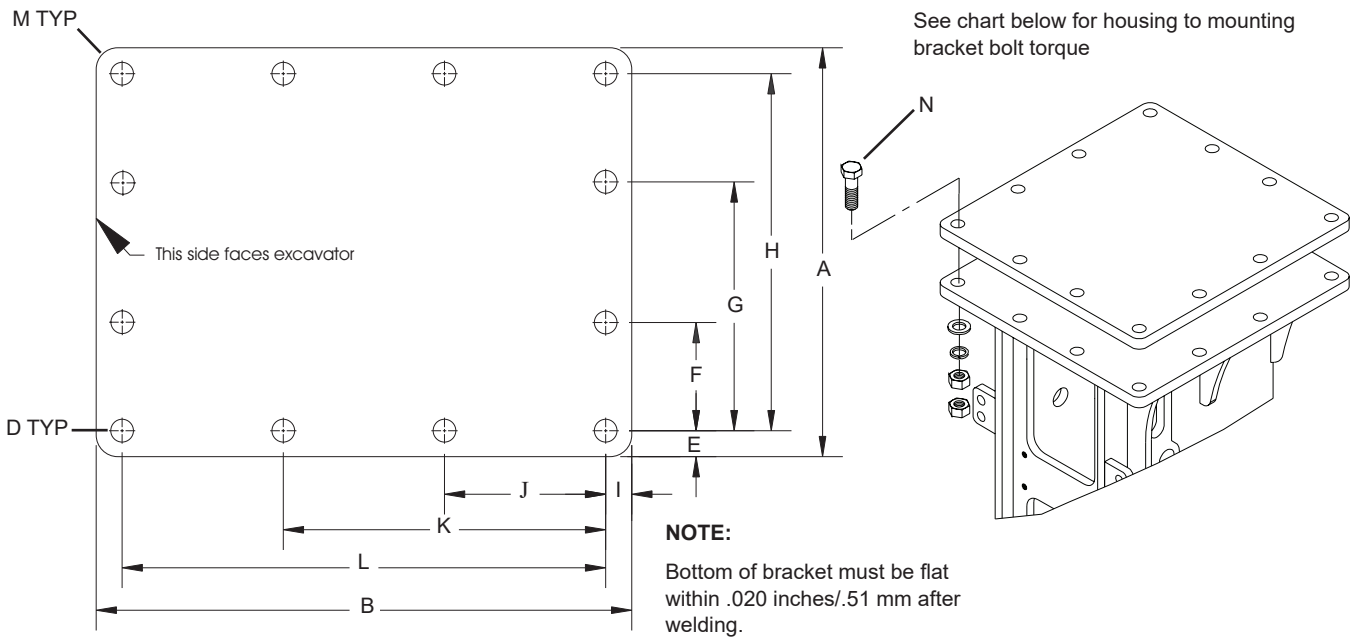

	MBX138 MBX208	MBX258 MBX308 MBX358	MBX408 MBX458	MBX608
A	19.606 in. / 498 mm	23.228 in. / 590 mm	27.953 in. / 710 mm	29.921 in. / 760 mm
B	25.197 in. / 640 mm	29.921 in. / 760 mm	32.283 in. / 820 mm	35.276 in. / 896 mm
Thickness	1.000 in. / 25 mm	1.000 in. / 25 mm	1.500 in. / 38 mm	1.500 in. / 38 mm
D	1.102 in. / 28 mm	1.024 in. / 26 mm	1.496 in. / 38 mm	1.496 in. / 38 mm
E	1.772 in. / 45 mm	1.614 in. / 41 mm	1.575 in. / 40 mm	2.362 in. / 60 mm
F	4.803 in. / 122 mm	6.654 in. / 169 mm	7.874 in. / 200 mm	8.661 in. / 220 mm
G	11.260 in. / 286 mm	13.346 in. / 339 mm	16.929 in. / 430 mm	16.535 in. / 420 mm
H	16.063 in. / 408 mm	20.000 in. / 508 mm	24.803 in. / 630 mm	25.197 in. / 640 mm
I	1.772 in. / 45 mm	1.378 in. / 35 mm	1.575 in. / 40 mm	2.362 in. / 60 mm
J	7.087 in. / 180 mm	8.858 in. / 225 mm	9.646 in. / 245 mm	10.157 in. / 258 mm
K	14.567 in. / 370 mm	18.307 in. / 465 mm	19.488 in. / 495 mm	20.394 in. / 518 mm
L	21.654 in. / 550 mm	27.165 in. / 690 mm	29.134 in. / 740 mm	30.551 in. / 776 mm
M	1.575 in. / 40 mm	1.181 in. / 30 mm	1.575 in. / 40 mm	1.575 in. / 40 mm
(N) Mounting Bracket Bolt Torque	60 kg-m / 434 ft lbs	60 kg-m / 434 ft lbs	160 kg-m / 1157 ft lbs	

ACCESSORIES

Attaching Kits.....	Consult Dealer
Charge Hose Assy (Valve, Hose, for nitrogen tank & charge valve connections).....	505232
Adapter Assy (Required to charge main accumulator).....	33300
Adapter (Short) (Required to Charge Main Accumulator on MBX15).....	33464
Charge Adapter Kit (Includes 33300 & 33464).....	33465
Charge Kit Assembly (Includes 505232 hose, 28257 Tester, and 372047 Box).....	34892
Accumulator Tester.....	28257
Eyebolt, M12.....	32606
Eyebolt, M16.....	32607
Eyebolt, M20.....	32608
Eyebolt, M24.....	52729
Eyebolt, M30.....	28547
Operation Manual.....	71554

UPPER BUMPER

OLD

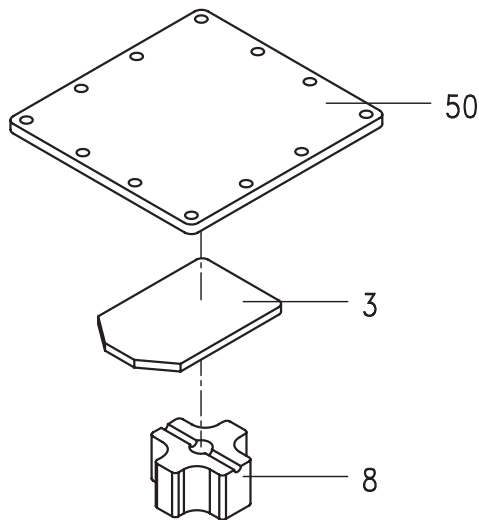

NEW

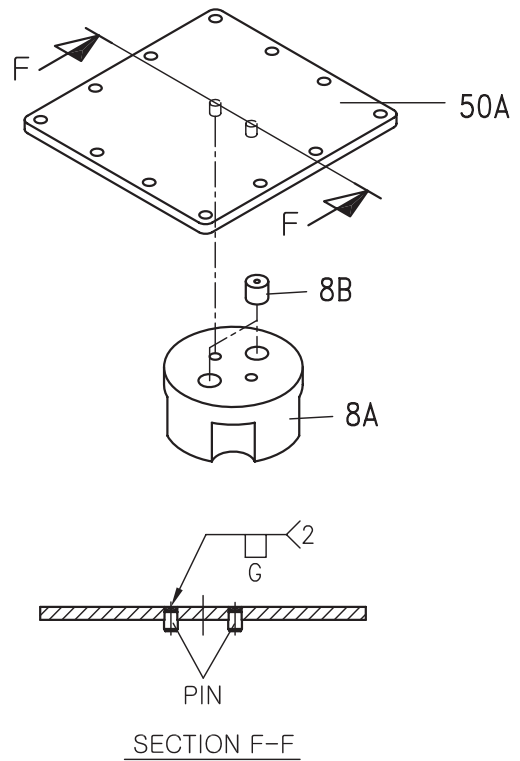

March 2012 and earlier

MBX408 Serial Number 40B 10G11 thru 11A10, 40C 11F21 thru 12B05

MBX458 Serial Number 45B 10G10 thru 11B06, 45C 11i06 thru 11L24, 45C 12A08

ITEM	PART NAME	PART NO.	QTY
3	UPPER BUMPER SUPPORT	69418	1
8	UPPER BUMPER	69419	1

April 2012

MBX408 Serial Number 40C 12A07 & UP

MBX458 Serial Number 45C 12A01 thru 12A07, and 12D & UP

ITEM	PART NAME	PART NO.	QTY
8A	UPPER BUMPER	72984	1
8B	UPPER BUMPER PLUG	72985	2

Note: This change on the MBX408 and MBX458 from old to new upper bumper happened in April 2012. If ordering the new items 8A and 8B your mounting bracket must have the two pins installed in the mounting bracket (see page 31)

MBX 408, 458, 608 COVER PLATE

COVER PLATE MBX408 & MBX458

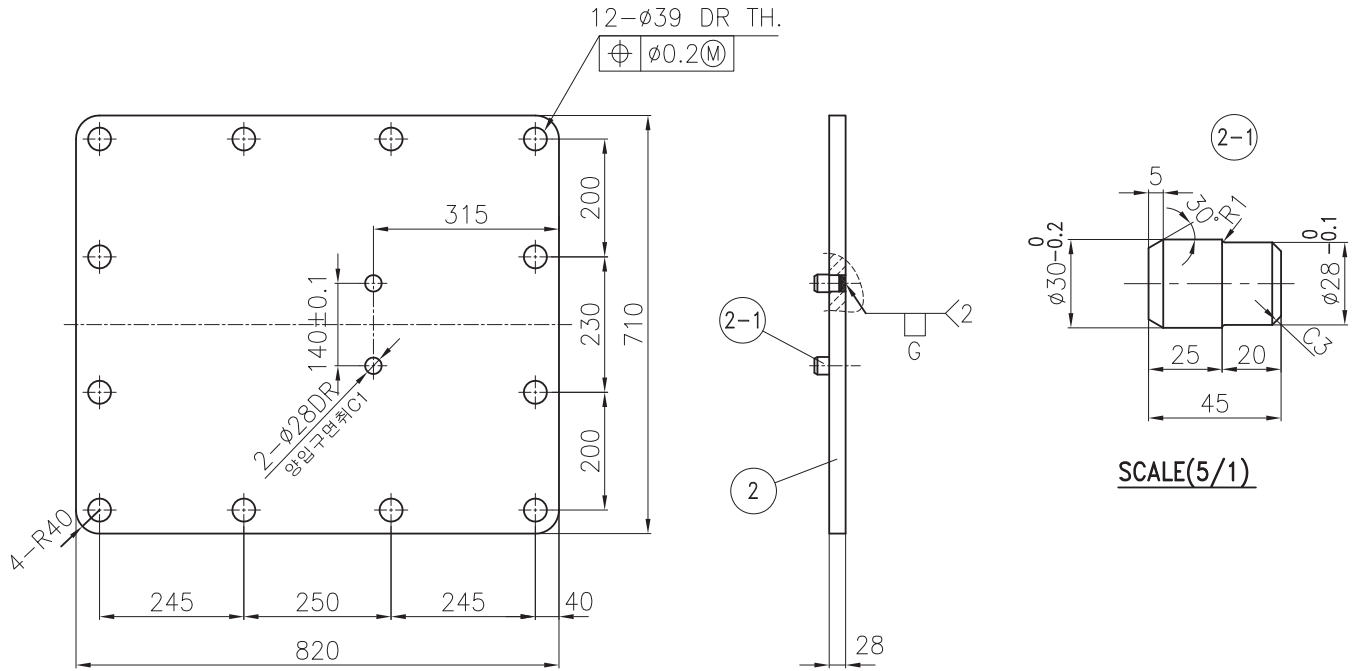

COVER PLATE MBX608

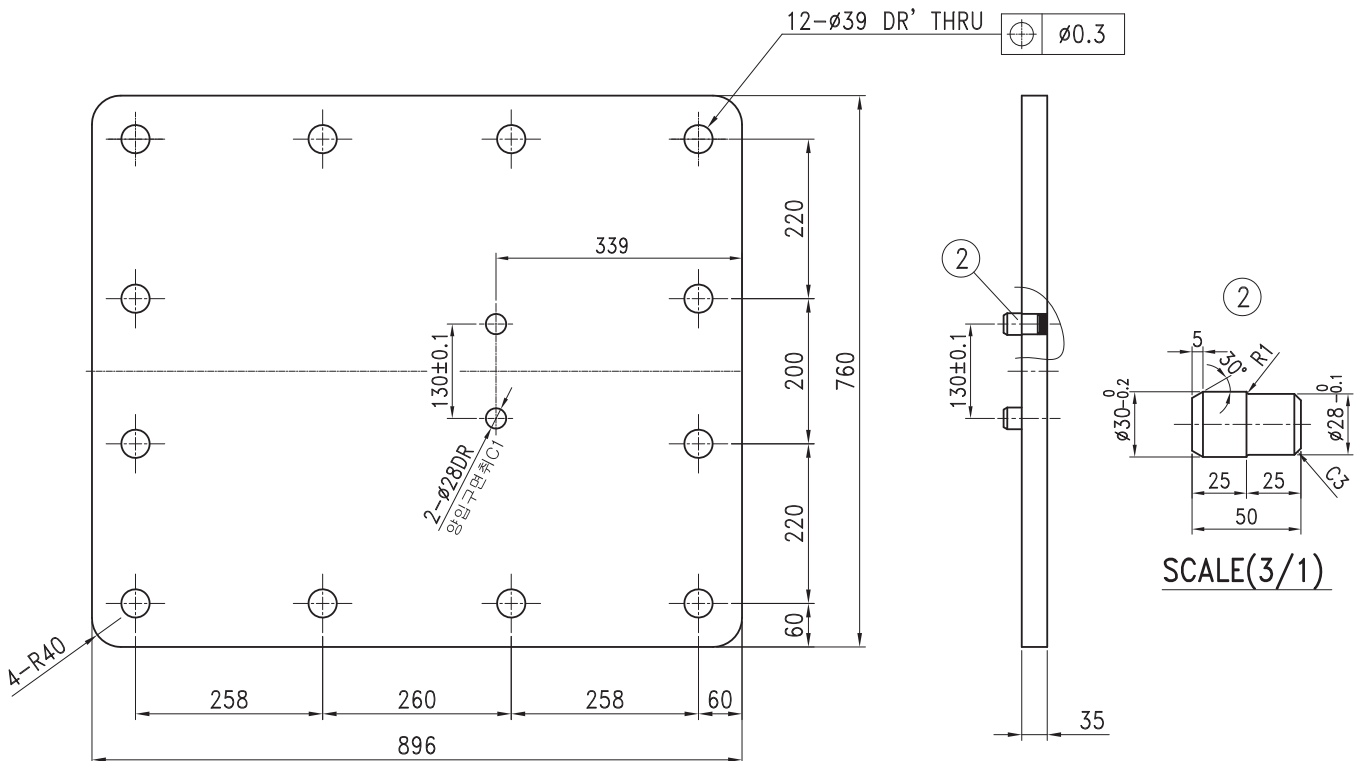

MBX608 CYLINDER AND LOWER BODY CHANGE IN 2012

Note: A design change took place in February 2012 on the MBX608 only of the Cylinder and Lower Body. The cylinder hub diameter changed in size along with the bore in the Lower Body (See Below).

The Cylinder hub diameter changed from 8.661 (220mm) to 9.055 (230mm).

The Lower Body bore diameter changed from 8.661 (220mm) to 9.055 (230mm).

The number of Dowel Pins also changed from a quantity of 1 to 2.

See Serial Number breaks below.

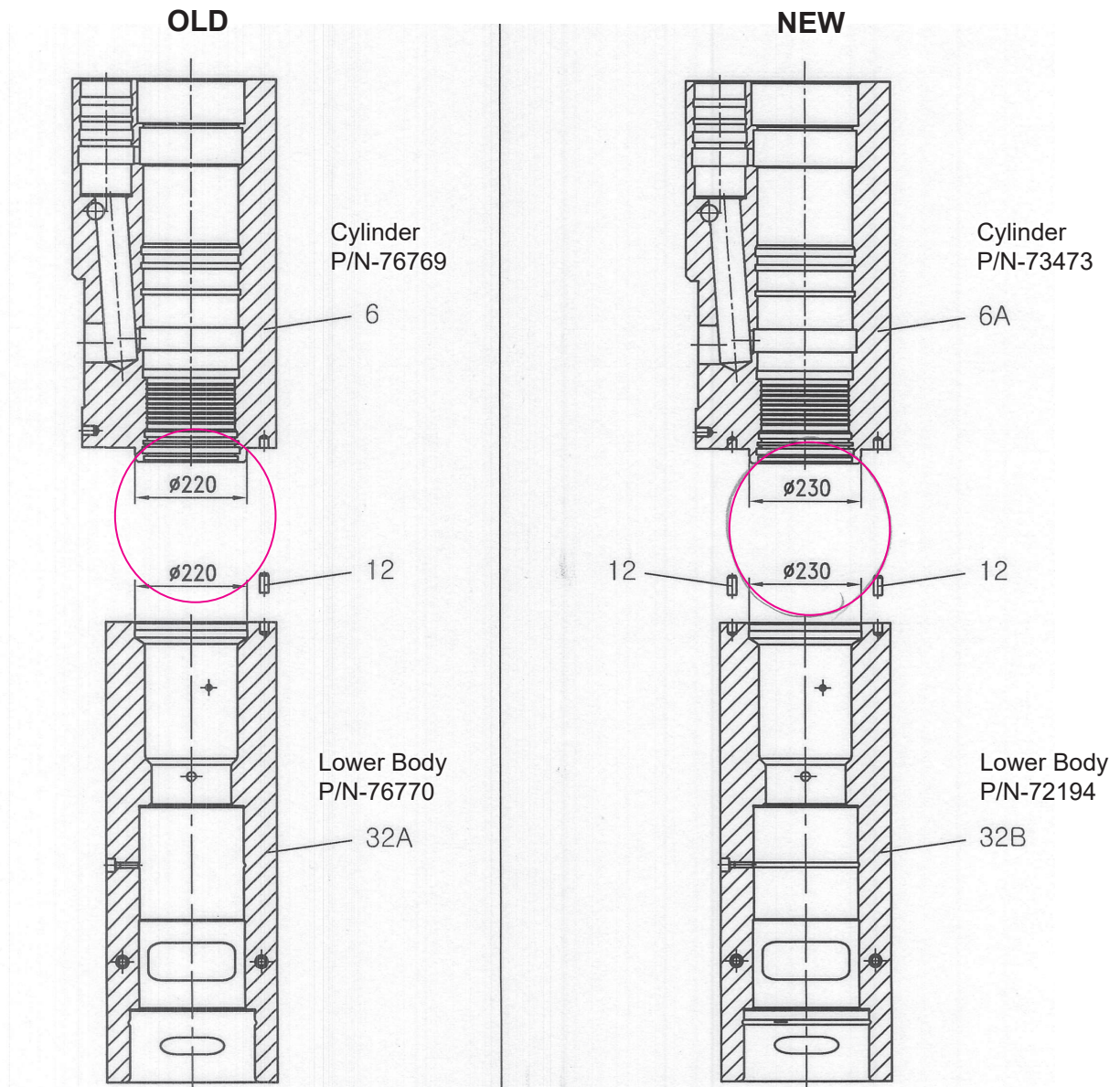

Old Serial Numbers:
50B, 50C

New Serial Numbers:
50D and Above

FLOW TEST PROCEDURES

The correct performance of this procedure will verify if the auxiliary circuit of the carrier is adequate to properly operate a STANLEY attachment.

This procedure is generic in form. It is the end users responsibility to ensure that this procedure will work with his specific type of equipment.

If an adequate flow meter is not available contact your STANLEY Distributor for assistance.

TEST PROCEDURE

1. With the auxiliary circuit (or kit) completely installed connect the flow meter between the tool inlet and outlet hoses.

Note: Always use the hoses that are supplied for the attachment and make sure the machine hydraulic oil is between 90 to 120 °F. This will assure correct readings and adjustments.

2. With the machine setting at the mode that's going to be used to operate the attachment record the GPM _____.

Locate the correct flow for the attachment in the manual under the specification section. Adjust the machine to the correct GPM.

Note: If possible, always set the machine to the highest GPM output mode. This will prevent the operator from over flowing the attachments.

3. Once the correct GPM flow is achieved fully open the restrictor on the flow meter.
4. With the machine in the attachment mode set in step 2 record the back-pressure. At this point the pressure reading on the pressure gauge is the back-pressure in the circuit. This pressure must not exceed 200 psi/13.5 bar.

Excessive back-pressure will slow the attachments operation and lead to premature seal failures and over heating.

Record the back-pressure _____ psi.

5. Close the restrictor valve on the flow meter until the attachment relief starts to crack or open. The relief valve opens when the flow rate (GPM), indicated on the flow meter begins to decline rapidly. Locate the tools operating system relief pressure in the specification section in the manual. Adjust attachment relief to specification.

Note: The relief valve pressure must be greater than the operating pressure of the attachment and three times the back-pressure. Never use the relief valve to control the flow rate in the circuit. Cracking

pressure means the loss of 4 or more GPM.

Record the relief cracking pressure _____ psi.

Example:

Operation pressure of a breaker is 2700 psi. Back-pressure is 150 psi. A good rule to follow when setting the relief, multiply the back pressure by 3 then add this number to the operation pressure of the attachment.

Operating Pressure	2700 psi
Back-pressure	450 psi
Operating pressure of the tool	3150 psi

The relief valve setting must be greater than the estimated operating pressure of the tool. If the setting is lower, damage to the circuit may occur. Excess heat will be generated in the circuit which will damage the attachment and carrier.

HEAT LOAD TEST

With the installation kit properly installed and adjusted per the above procedure, conduct the heat load test as follows.

1. Connect the flow meter between the tool inlet and outlet hoses.
2. With the carrier set in the attachment mode, restrict the flow meter until a pressure of 1000 psi is achieved. This pressure must be maintained throughout the heat test.

Note: Closing of the restrictor may be required as the temperature increases.

Monitor the oil temperature from the flow meter until no change is noted. Record the time required for oil to stabilize. Record the surrounding temperature (ambient temperature). Record the time required to stabilize _____ minutes.

Record the stabilized oil temperature _____ °F.

Record the ambient temperature _____ °F.

The "heat rise" is calculated as the stabilized temperature minus the ambient temperature.

SPECIFICATIONS

Impact Energy Class	ft lbs J	MBX138	MBX208	MBX258	MBX308	MBX358	MBX408	MBX458	MBX608
Blows Per Minute	bpm	450-630	400-530	350-600	400-490	350-750	300-600	300-550	200-350
Flow Range	GPM LPM	21-29 80-110	24-32 90-120	26-40 100-150	33-40 125-150	42-50 160-190	50-66 190-250	50-66 190-250	55-77 210-290
Hydraulic Operating Pressure	psi	2175-2465	2175-2465	2320-2610	2320-2610	2320-2610	2320-2610	2320-2610	2320-2610
	bar	150-170	150-170	160-180	160-180	160-180	160-180	160-180	160-180
System Relief Pressure (minimum cracking)	psi	3050	3050	3200	3200	3200	3200	3200	3200
	bar	210	210	220	220	220	220	220	220
Oil Temperature (max)	F	176 °F	176 °F	176 °F	176 °F	176 °F	176 °F	176 °F	176 °F
	C	80 °C	80 °C	80 °C	80 °C	80 °C	80 °C	80 °C	80 °C
Hose Diameter (min)	inch	3/4	1	1	1	1	1 1/4	1 1/4	1 1/4
	mm	19	25	25	25	25	32	32	32
Adapter Fitting Size & Type		Male JIC 37° Flare 1-1/16 × 12 UNF		Male JIC 37° Flare 1-5/16 × 12 UNF			Male JIC 37° Flare 1-5/8 × 12 UNF		
Weight (w/Tool Bit)	Lbs	1925	2640	3300	3800	4100	5450	5460	7560
	kg	875	1200	1500	1730	1880	2480	2485	3440
Length (w/Tool Bit)	inch	74	82	87	91	98	103	103	123
	mm	1890	2090	2210	2320	2490	2630	2630	3160
Tool Diameter	inch	3.9	4.9	5.3	5.5	5.9	6.1	6.24	6.825
	mm	100	125	135	140	150	155	160	175
Tool Working Length	inch	16.9	18.5	22.4	22.8	27.2	25.2	26.2	30
	mm	430	470	570	580	690	640	672	770
Main Accumulator Charge Pressure	psi	247 +/- 7	247 +/- 7	218 +/- 7	218 +/- 7	87 +/- 7	247 +/- 7	123 +/- 0.5	217 +/- 7
	bar	17 +/- 0.5	17 +/- 0.5	15 +/- 0.5	15 +/- 0.5	6 +/- 0.5	17 +/- 0.5	8.5 +/- 0.5	15 +/- 0.5
Side Accumulator Charge Pressure	psi	—	—	—	870 +/- 7.25	870 +/- 7.25	870 +/- 7.25	870 +/- 7.25	870 +/- 7.25
	bar	—	—	—	60 +/- 0.5	60 +/- 0.5	60 +/- 0.5	60 +/- 0.5	60 +/- 0.5
Sound Power Level (LW)	dBA	116	115	120	120	120	124	125	125
	Lbs	19,800-35,200	26,000-50,000	35,200-55,000	39,600-65,000	50,000-70,000	58,000-88,000	60,000-99,000	78,000-130,000
Carrier Size	kg	8,981-15,966	11,793-22,680	15,966-24,948	17,962-29,483	22,680-31,751	26,308-39,916	27,216-44,906	35,380-58,967

Note: Weights, dimensions and operating specifications listed on this sheet are subject to change without notice. Where specifications are critical to your application, please consult the factory.

SERIAL NUMBER LOCATIONS

MODELS: MBX138, MBX208, MBX258, MBX308, MBX608

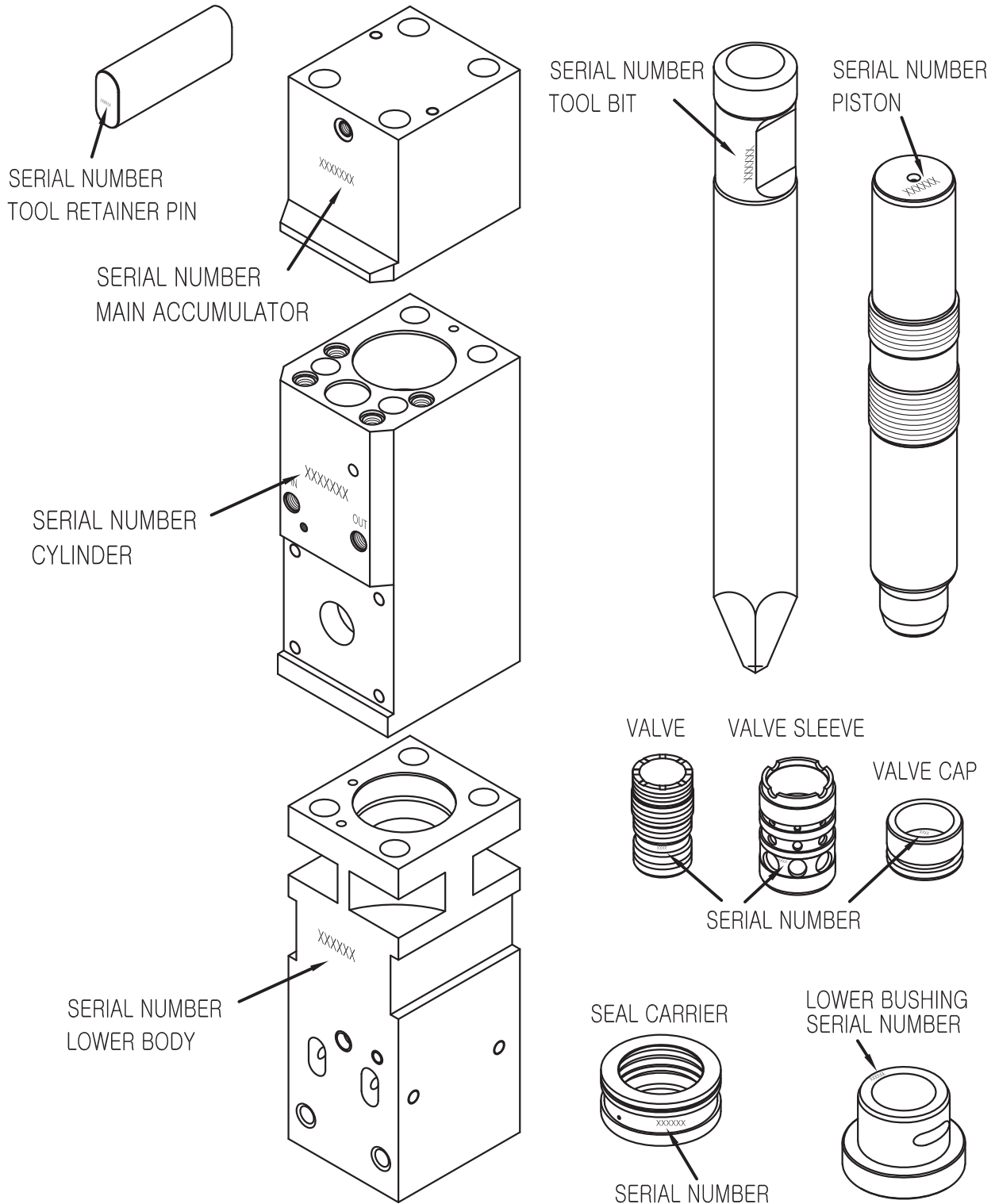

SERIAL NUMBER LOCATIONS

MODELS: MBX358, MBX408, MBX458

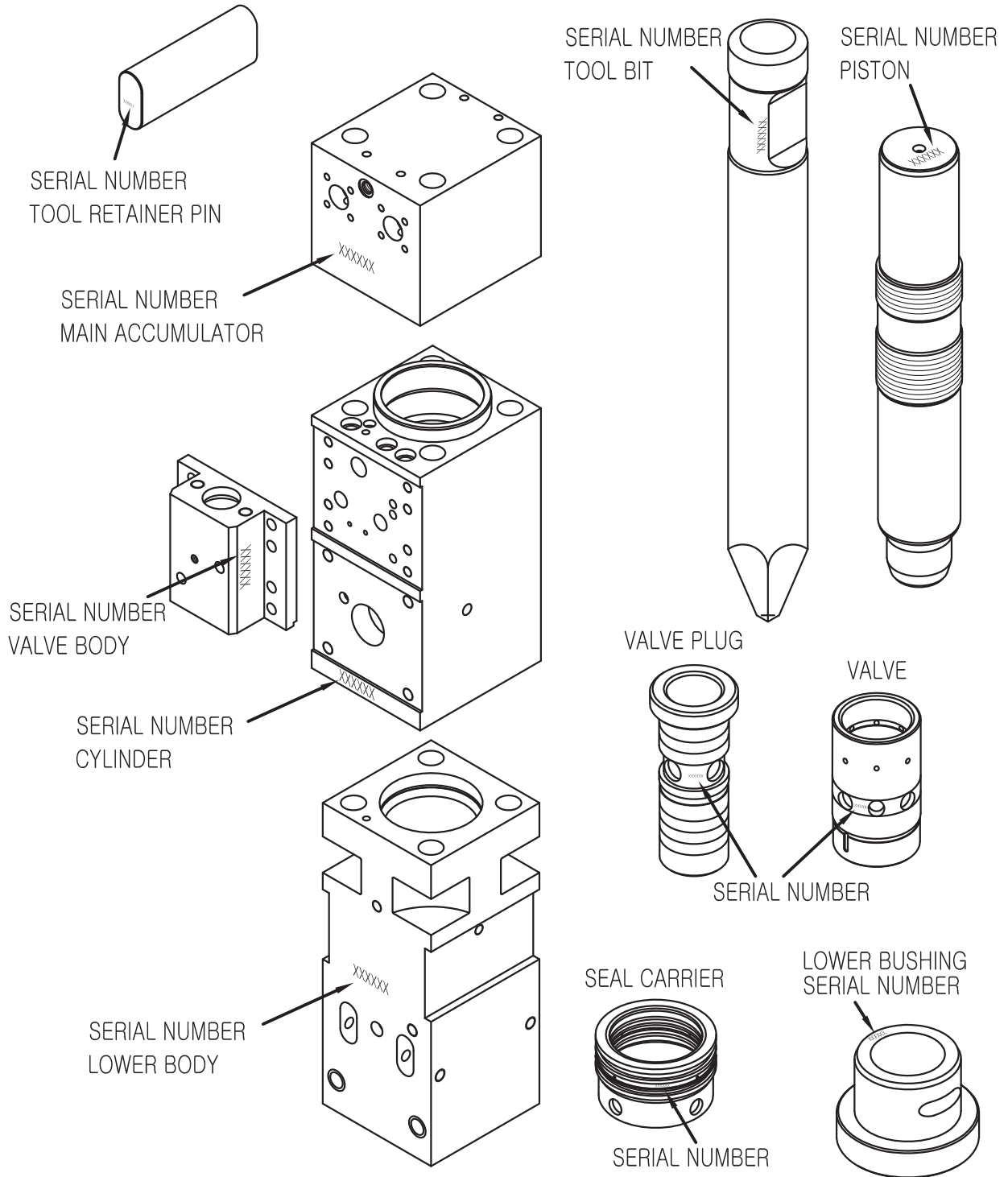

MBX138 POWERCELL ILLUSTRATION

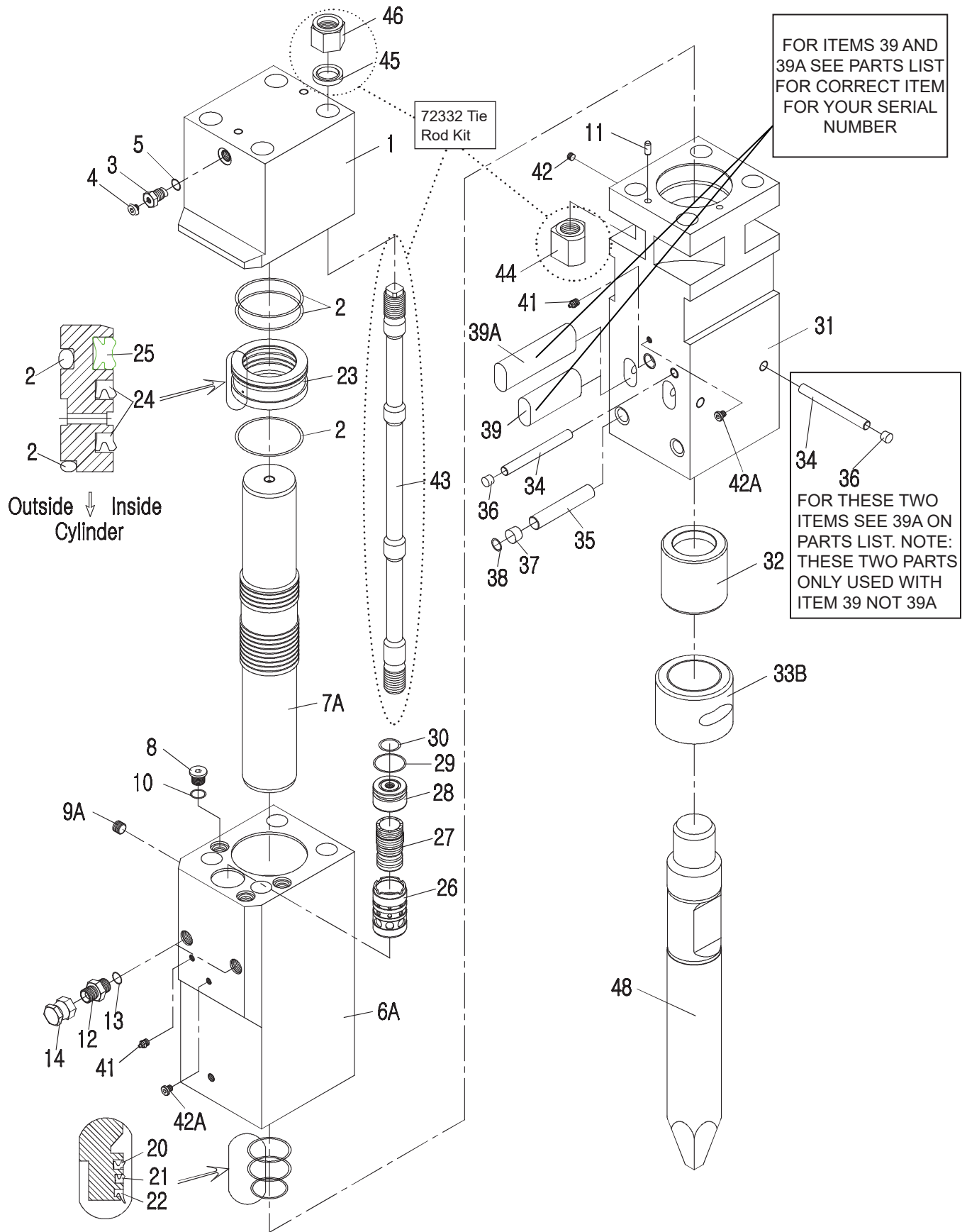

MBX138 POWER CELL PARTS LIST

ITEM	P/N	QTY	DESCRIPTION
1	68677	1	MAIN ACCUMULATOR
2	68878	3	O-RING
3	68679	1	CHARGE VALVE
4	68680	1	PLUG
5	68681	1	O-RING
6A	73467	1	CYLINDER
7A	73474	1	PISTON
8	68684	3	PLUG
9A	68685	1	PLUG
10	68686	3	O-RING
11	68687	2	DOWEL PIN
12	68688	2	ADAPTER
13	68689	2	O-RING
14	68690	2	ADAPTER CAP
20	68691	1	SEAL BUFFER
21	68692	1	SEAL, U-CUP
22	68693	1	SEAL, DUST
23	68694	1	SEAL CARRIER
24	68695	2	SEAL, U CUP
25	68696	1	SEAL, GAS
26	68697	1	VALVE SLEEVE
27	68698	1	VALVE
28	68699	1	VALVE CAP
29	68700	1	O-RING
30	68701	1	O-RING
31	68702	1	LOWER BODY
32	68703	1	TOOL STOP
33B	71629	1	LOWER BUSHING MBX138
34	68705	2	RETAINER PIN
35	68706	2	RETAINER PIN
36	68707	2	RUBBER PLUG
37	68708	2	RUBBER PLUG
38	68709	2	SNAP RING
39	68710	2	TOOL RETAINER PIN (USED ON BREAKERS WITH S/N-12A 13I04 AND BELOW) NOTE: ITEMS 34 & 36 ARE USED WITH THIS RETAINER PIN.
39A	73452	2	TOOL RETAINER PIN (USED ON BREAKERS WITH S/N-12A 13I05 AND ABOVE) NOTE: ITEMS 34 & 36 ARE NOT USED WITH THIS RETAINER PIN.
41	68711	2	GREASE NIPPLE
42	68712	1	PLUG
42A	69102	2	PLUG

ITEM	P/N	QTY	DESCRIPTION
KT	72332	1	TIE ROD KIT (INCL ONE EACH OF ITEMS 43 THRU 46)
43	68713	4	TIE ROD
44	68714	4	LOWER TIE ROD NUT
45	68715	4	TIE ROD WASHER
46	68716	4	UPPER TIE ROD NUT
48	71631	1	TOOLBIT MBX138 CROSS CUT CHISEL
SEE PAGE 61 FOR ADDITIONAL TOOL BITS.			
KT	68721		SEAL KIT

MBX138 HOUSING PARTS

NOTE: See pages 7 & 8 for sticker information and part numbers.

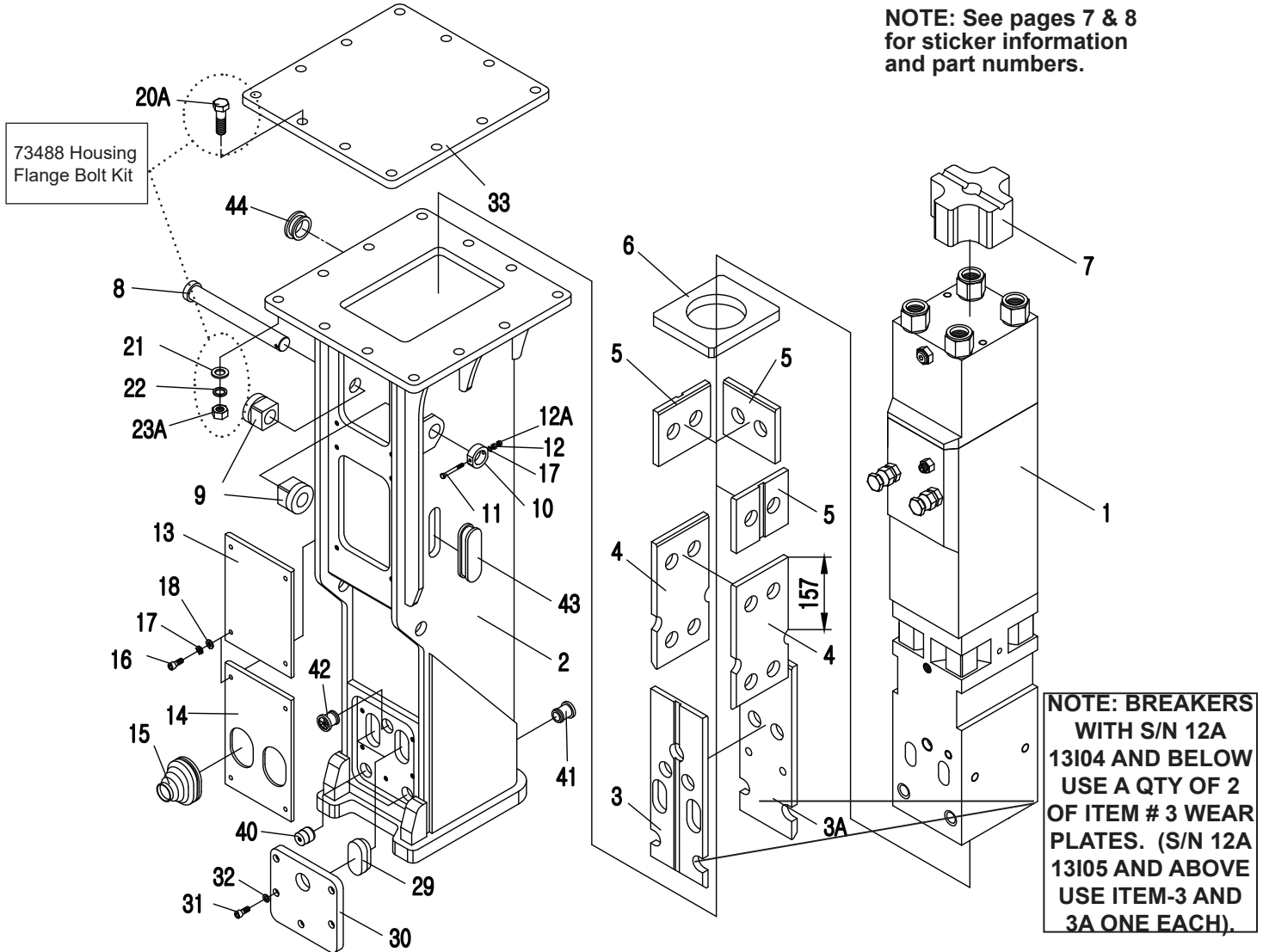

ITEM	P/N	QTY	DESCRIPTION
1	72271	1	POWER CELL
2	72273	1	HOUSING
3	72287	1 / 2	WEAR PLATE (SEE NOTE ABOVE)
3A	73451	1	WEAR PLATE (SEE NOTE ABOVE)
4	72269	2	WEAR PLATE
5	68726	3	WEAR PLATE
6	72270	1	LOWER BUMPER
7	68728	1	UPPER BUMPER
8	68729	1	GUIDE PIN
9	68730	2	WEAR BUSHING
10	68731	1	STOP RING
11	68732	1	CAPSCREW
12	68733	1	HEX NUT
12A	71635	1	NYLON NUT
13	68734	1	UPPER WINDOW COVER
14	68735	1	LOWER WINDOW COVER
15	68736	2	RUBBER BOOT

ITEM	P/N	QTY	DESCRIPTION
16	68737	8	CAPSCREW
17	68738	9	LOCK WASHER
18	68739	8	WASHER
KT	73488	1	HOUSING FLANGE BOLT KIT (INCL ONE EA OF ITEMS 20A THRU 23A)
20A	72256	12	CAPSCREW
21	68741	12	WASHER
22	68742	12	LOCK WASHER
23A	73483	12	NYLON NUT
29	68744	2	TOOL RETAINER PLUG
30	71671	1	TOOL PIN RETAINER PLATE
31	68746	8	CAPSCREW
32	68747	8	LOCK WASHER
40	71636	2	RUBBER PLUG
41	71637	4	RUBBER PLUG
42	71638	1	RUBBER PLUG
43	71639	2	RUBBER PLUG
44	82580	1	RUBBER PLUG

MBX208 POWER CELL ILLUSTRATION

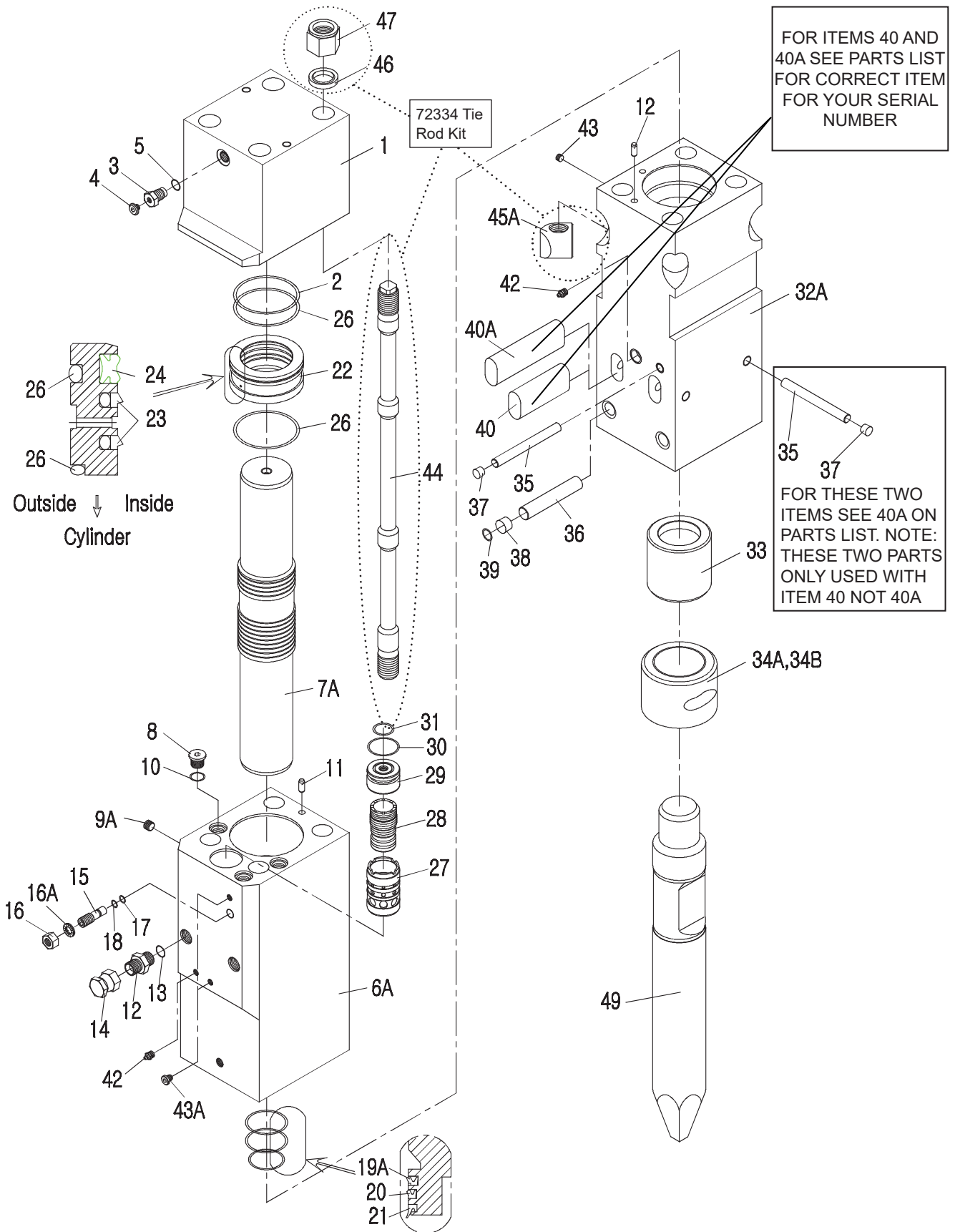

MBX208 POWER CELL PARTS LIST

ITEM	P/N	QTY	DESCRIPTION
1	68801	1	MAIN ACCUMULATOR
2	68802	1	O-RING
3	68679	1	CHARGE VALVE
4	68680	1	PLUG
5	68681	1	O-RING
6A	73468	1	CYLINDER
7A	73475	1	PISTON
8	68805	3	PLUG
9A	68685	1	PLUG
10	68806	3	O-RING
11	68687	2	DOWEL PIN
12	68807	2	ADAPTER
13	68808	2	O-RING
14	68809	2	ADAPTER CAP
15	68810	1	CYLINDER ADJUSTER
16	68811	1	ADJUSTER NUT
16A	71640	1	LOCK WASHER
17	68812	1	O-RING
18	68813	1	BACK-UP RING
19A	68814	1	SEAL, BUFFER
20	68815	1	SEAL, U-CUP
21	68816	1	SEAL, DUST
22	68817	1	SEAL, CARRIER
23	68818	2	SEAL, STEP
24	68819	1	SEAL, GAS
26	68820	2	O-RING
27	68821	1	VALVE SLEEVE
28	68822	1	VALVE
29	68823	1	VALVE CAP
30	68824	1	O-RING
31	68825	1	O-RING
32A	71641	1	LOWER BODY MBX208
33	68827	1	TOOL STOP
34B	71642	1	LOWER BUSHING
35	68829	2	RETAINER PIN
36	68830	2	RETAINER PIN
37	68831	2	RUBBER PLUG
38	68832	2	RUBBER PLUG
39	68833	2	SNAP RING

ITEM	P/N	QTY	DESCRIPTION
40	68834	2	TOOL RETAINER PIN (USED ON BREAKERS WITH S/N-17E 14A00 AND BELOW) NOTE: ITEMS 35 & 37 ARE USED WITH THIS RETAINER PIN.
40A	73454	2	TOOL RETAINER PIN (USED ON BREAKERS WITH S/N-17E 14A01 AND ABOVE) NOTE: ITEMS 35 & 37 ARE NOT USED WITH THIS RETAINER PIN.
42	68711	2	GREASE NIPPLE
43	68712	2	PLUG
43A	69102	2	PLUG
KT	72334	1	TIE ROD KIT (INCL ONE EACH OF ITEMS 44, 45A, 46 AND 47)
44	68835	4	TIE ROD
45A	71643	4	LOWER TIE ROD NUT MBX208
46	68837	4	TIE ROD WASHER
47	68838	4	UPPER TIE ROD NUT
49	71645	1	TOOL BIT MBX208 CROSS CUT CHISEL
SEE PAGE 61 FOR ADDITIONAL TOOL BITS.			
KT	68843	1	SEAL KIT

MBX208 HOUSING PARTS

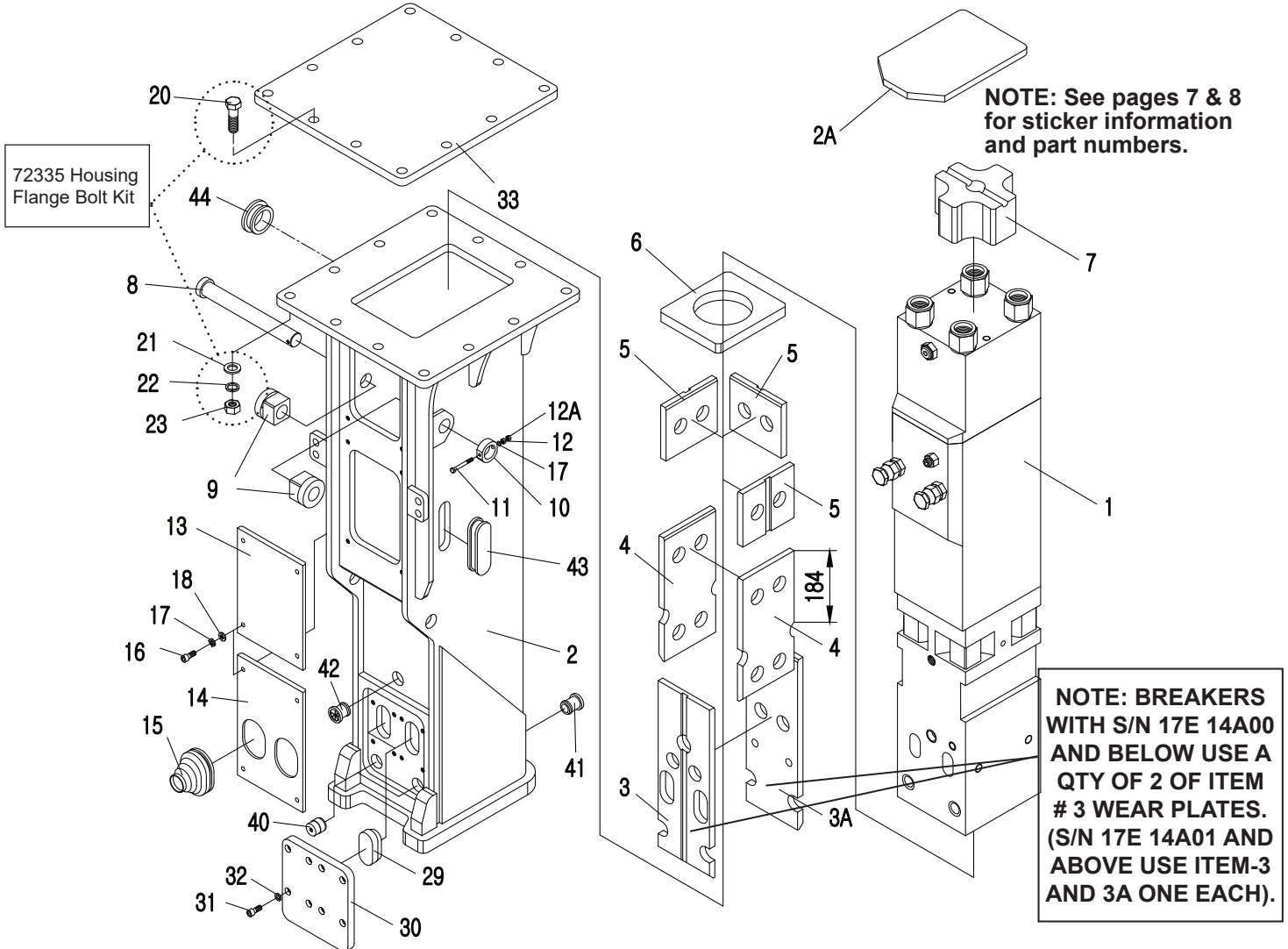

ITEM	P/N	QTY	DESCRIPTION
1	72274	1	POWER CELL
2	72296	1	HOUSING
2A	71649	1	UPPER BUMPER SUPPORT
3	72275	1 / 2	WEAR PLATE (SEE NOTE ABOVE)
3A	73453	1	WEAR PLATE (SEE NOTE ABOVE)
4	72276	2	WEAR PLATE
5	68849	3	WEAR PLATE
6	72277	1	LOWER BUMPER
7	68851	1	UPPER BUMPER
8	68852	1	GUIDE PIN
9	68853	2	WEAR BUSHING
10	68854	1	STOP RING
11	68855	1	CAPSCREW
12	68733	1	HEX NUT
12A	71635	1	NYLON NUT
13	68857	1	UPPER WINDOW COVER
14	68858	1	LOWER WINDOW COVER
15	68859	2	RUBBER BOOT

ITEM	P/N	QTY	DESCRIPTION
16	68737	8	CAPSCREW
17	68738	9	LOCK WASHER
18	68739	8	WASHER
KT	72335	1	HOUSING FLANGE BOLT KIT (INCL ONE EA OF ITEMS 20 THRU 23)
20	68740	12	CAPSCREW
21	68741	12	WASHER
22	68742	12	LOCK WASHER
23	68743	12	NYLON NUT
29	68860	2	TOOL RETAINER PLUG
30	71672	1	TOOL PIN RETAINER PLATE
31	68746	8	CAPSCREW
32	68747	8	LOCK WASHER
40	71636	2	RUBBER PLUG
41	71650	4	RUBBER PLUG
42	71638	1	RUBBER PLUG
43	71651	2	RUBBER PLUG
44	82582	1	RUBBER PLUG

MBX258 POWER CELL ILLUSTRATION

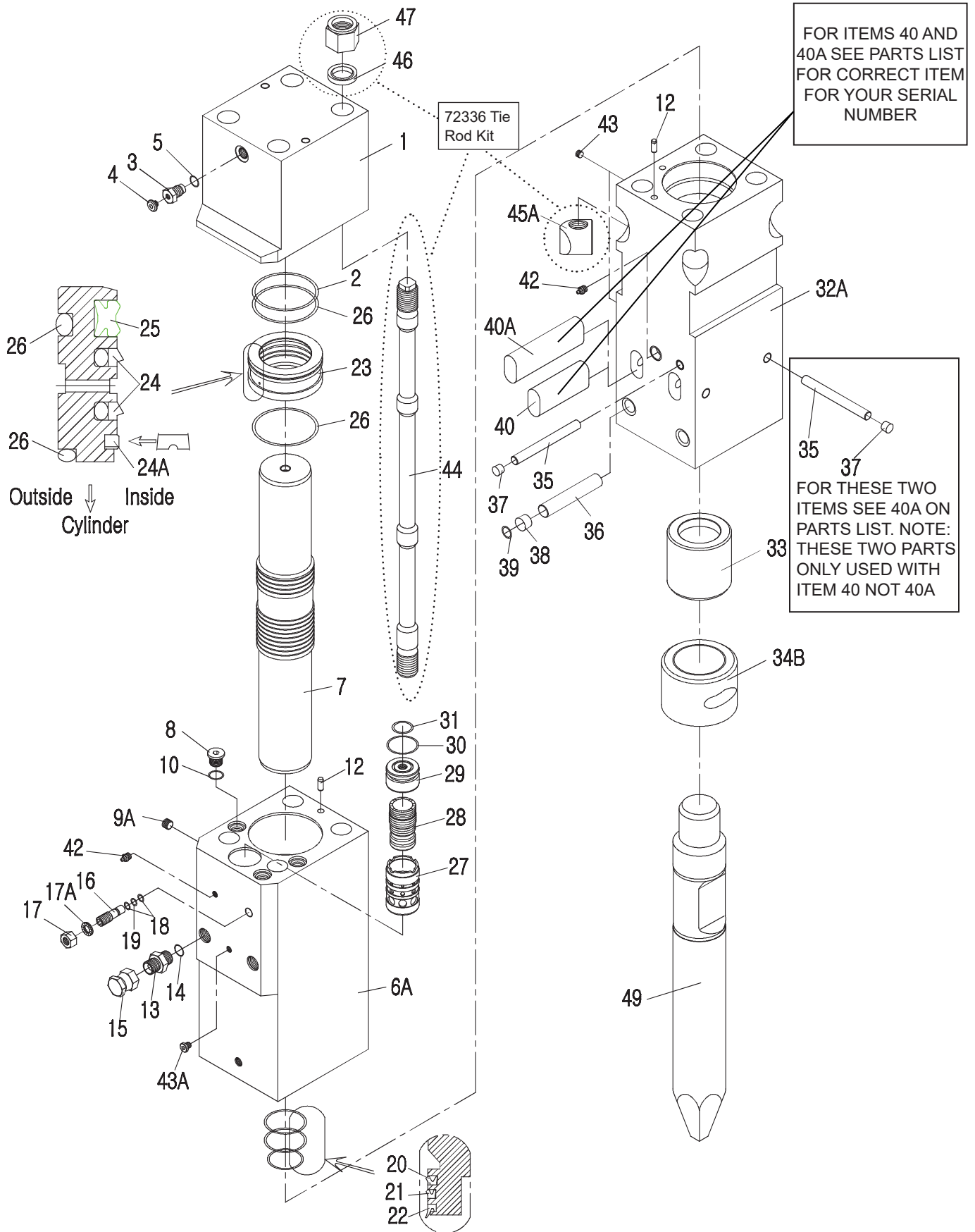

MBX258 POWER CELL PARTS LIST

ITEM	P/N	QTY	DESCRIPTION
1	68864	1	MAIN ACCUMULATOR
2	68865	1	O-RING
3	68679	1	CHARGE VALVE
4	68680	1	PLUG
5	68681	1	O-RING
6A	73469	1	CYLINDER
7	68867	1	PISTON
8	68868	3	PLUG
9A	68685	1	PLUG
10	68869	3	O-RING
12	68687	2	DOWEL PIN
13	68871	2	ADAPTER
14	68872	2	O-RING
15	68873	2	ADAPTER CAP
16	68874	1	CYLINDER ADJUSTER
17	68875	1	ADJUSTER NUT
17A	72255	1	LOCK WASHER
18	68876	2	O-RING
19	68877	1	BACK-UP RING
20	68878	1	SEAL, BUFFER
21	68879	1	SEAL, U-CUP
22	68880	1	SEAL, DUST
23	68881	1	SEAL CARRIER
24	68882	2	SEAL, STEP
24A	72261	1	BUFFER RING
25	68883	1	SEAL, GAS
26	68884	2	O-RING
27	68885	1	VALVE SLEEVE
28	68886	1	VALVE
29	68887	1	VALVE CAP
30	68888	1	O-RING
31	68889	1	O-RING
32A	71652	1	LOWER BODY MBX258
33	68891	1	TOOL STOP
34B	71653	1	LOWER BUSHING
35	68893	2	RETAINER PIN
36	68894	2	RETAINER PIN
37	68895	2	RUBBER PLUG
38	68896	2	RUBBER PLUG
39	68897	2	SNAP RING

ITEM	P/N	QTY	DESCRIPTION
40	68898	2	TOOL RETAINER PIN (USED ON BREAKERS WITH S/N-19E 14A00 AND BELOW) NOTE: ITEMS 35 & 37 ARE USED WITH THIS RETAINER PIN.
40A	73456	2	TOOL RETAINER PIN (USED ON BREAKERS WITH S/N-19E 14A01 AND ABOVE) NOTE: ITEMS 35 & 37 ARE NOT USED WITH THIS RETAINER PIN.
42	68711	2	GREASE NIPPLE
43	68712	2	PLUG
43A	69102	1	PLUG
KT	72336	1	TIE ROD KIT (INCL ONE EACH OF ITEMS 44, 45A, 46 & 47)
44	68899	4	TIE ROD
45A	71654	4	LOWER TIE ROD NUT MBX258
46	68901	4	TIE ROD WASHER
47	68902	4	UPPER TIE ROD NUT
49	71656	1	TOOL BIT MBX258 CROSS CUT CHISEL
SEE PAGE 61 FOR ADDITIONAL TOOL BITS.			
KT	68907	1	SEAL KIT

MBX258 HOUSING PARTS

NOTE: See pages 7 & 8 for sticker information and part numbers.

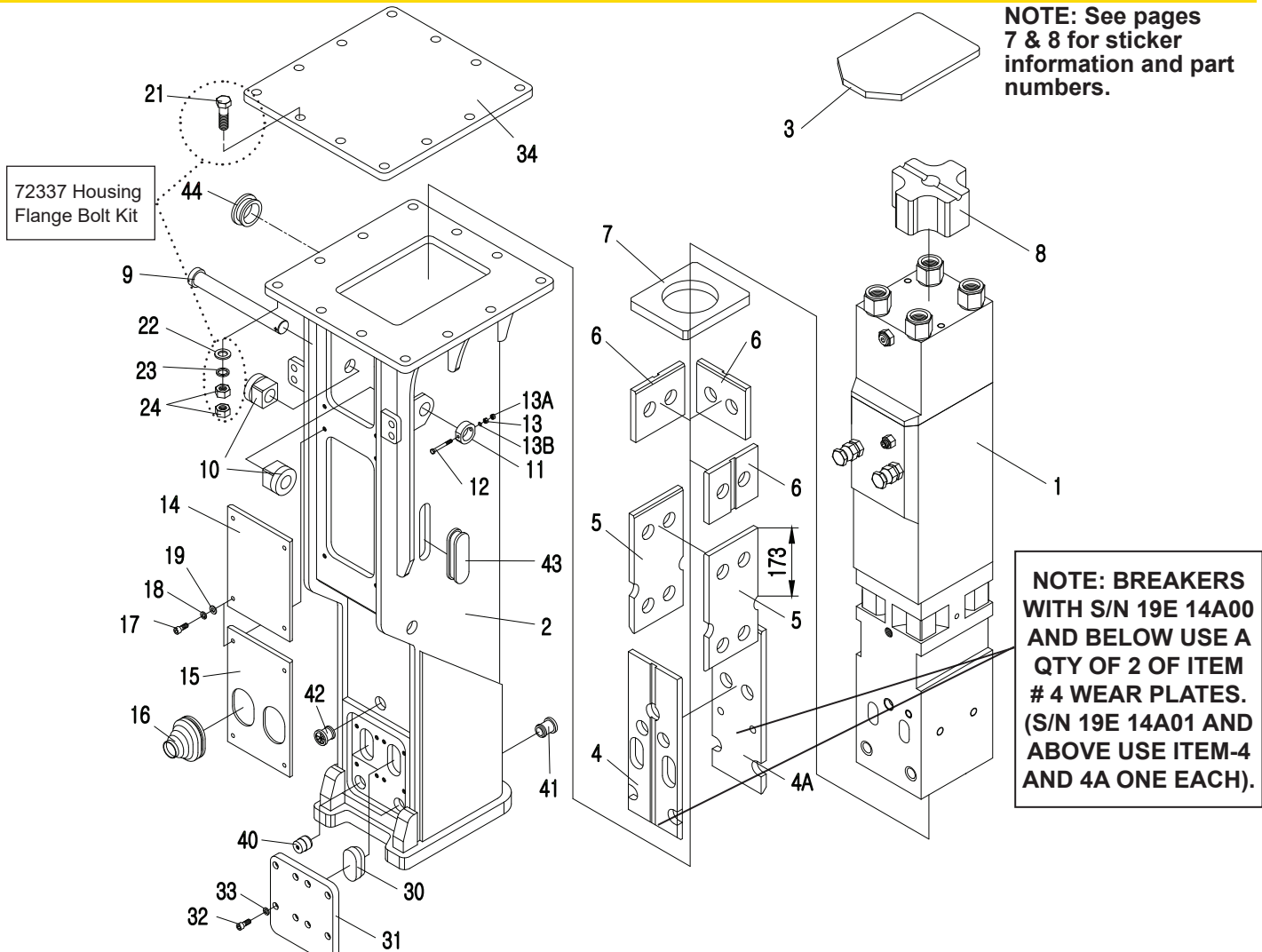

ITEM	P/N	QTY	DESCRIPTION
1	72278	1	POWER CELL
2	72279	1	HOUSING
3	68910	1	UPPER BUMPER SUPPORT
4	72280	1 / 2	WEAR PLATE (SEE NOTE ABOVE)
4A	73455	1	WEAR PLATE (SEE NOTE ABOVE)
5	72281	2	WEAR PLATE
6	68913	3	WEAR PLATE
7	72282	1	LOWER BUMPER
8	68915	1	UPPER BUMPER
9	68916	1	GUIDE PIN
10	68917	2	WEAR BUSHING
11	68918	1	STOP RING
12	68919	1	CAPSCREW
13	68733	1	HEX NUT
13A	71635	1	NYLON NUT
13B	68738	1	LOCK WASHER
14	68921	1	UPPER WINDOW COVER
15	72283	1	LOWER WINDOW COVER

ITEM	P/N	QTY	DESCRIPTION
16	68923	2	RUBBER BOOT
17	68924	10	CAPSCREW
18	68925	10	LOCK WASHER
19	68926	10	WASHER
KT	72337	1	HOUSING FLANGE BOLT KIT (INCL ONE EA OF ITEMS 21 THRU 23 & TWO EA OF ITEM 24)
21	72256	12	CAPSCREW
22	68741	12	WASHER
23	68742	12	LOCK WASHER
24	72257	24	NUT
30	68927	2	TOOL RETAINER PLUG
31	71673	1	TOOL PIN RETAINER PLATE
32	68746	8	CAPSCREW
33	68747	8	LOCK WASHER
40	71636	2	RUBBER PLUG
41	71650	4	RUBBER PLUG
42	71638	1	RUBBER PLUG
43	71651	2	RUBBER PLUG
44	82582	1	RUBBER PLUG

MBX308 POWER CELL ILLUSTRATION

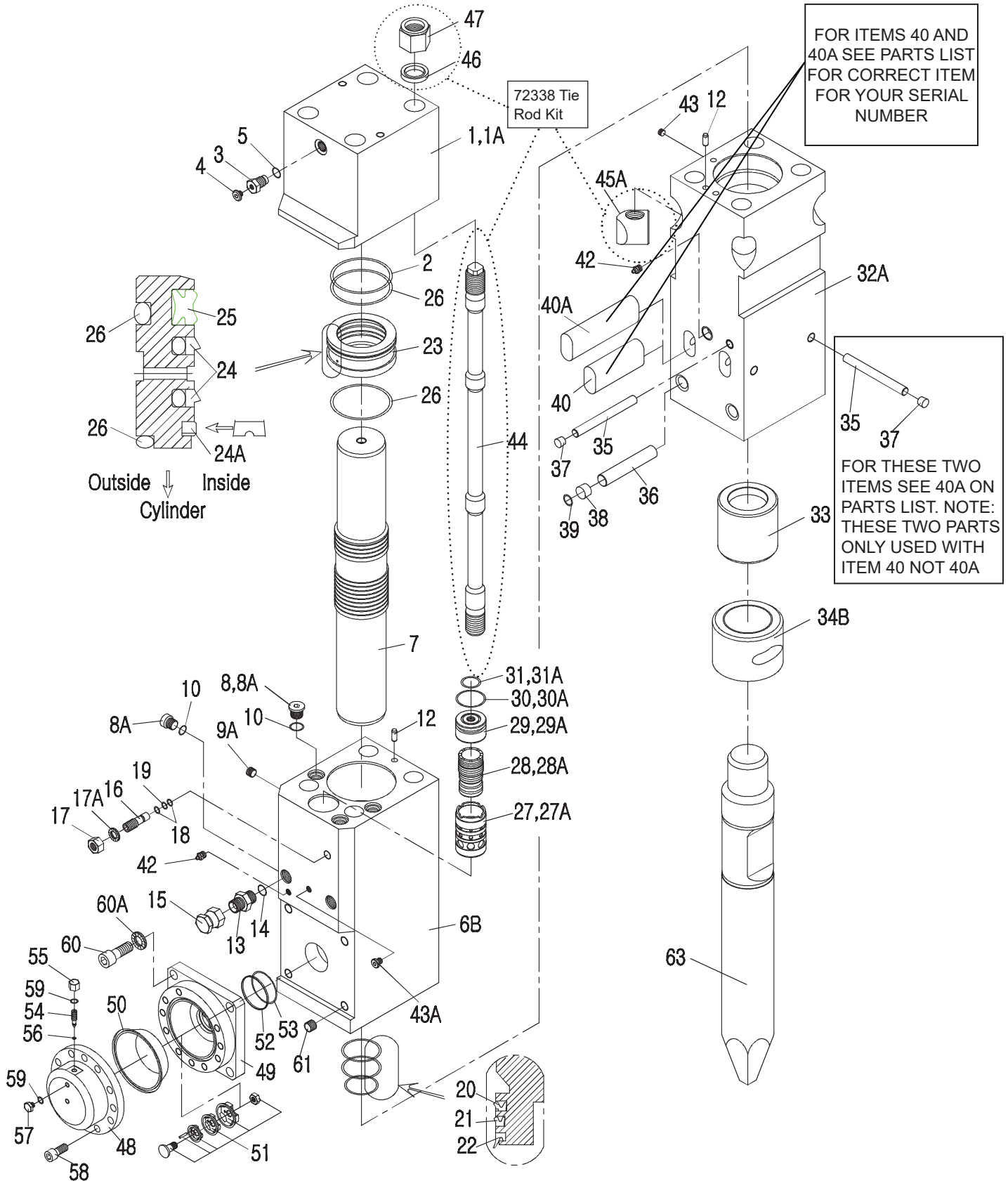

MBX308 POWER CELL PARTS LIST

ITEM	P/N	QTY	DESCRIPTION
1A	71660	1	MAIN ACCUMULATOR MBX308
2	68941	1	O-RING
3	68679	1	CHARGE VALVE
4	68680	1	PLUG
5	68681	1	O-RING
6B	73470	1	CYLINDER
7	68943	1	PISTON
8A	71662	4	PLUG
9A	68685	1	PLUG
10	68945	4	O-RING
11	—	—	NO ITEM
12	68687	2	DOWEL PIN
13	68947	2	ADAPTER
14	68948	2	O-RING
15	68949	2	ADAPTER CAP
16	68950	1	CYLINDER ADJUSTER
17	68951	1	ADJUSTER NUT
17A	72255	1	LOCK WASHER
18	68952	2	O-RING
19	68953	1	BACK-UP RING
20	68954	1	SEAL, BUFFER
21	68955	1	SEAL, U-CUP
22	68956	1	SEAL, DUST
23	68957	1	SEAL CARRIER
24	68958	2	SEAL, STEP
24A	72261	1	BUFFER RING
25	68959	1	SEAL, GAS
26	68960	2	O-RING
27A	68885	1	VALVE SLEEVE
28A	68886	1	VALVE
29A	68887	1	VALVE CAP
30A	68888	1	O-RING
31A	68889	1	O-RING
32A	71663	1	LOWER BODY
33	68967	1	TOOL STOP
34B	71664	1	LOWER BUSHING
35	68969	2	RETAINER PIN
36	68894	2	RETAINER PIN
37	68970	2	RUBBER PLUG
38	68971	2	RUBBER PLUG
39	68972	2	SNAP RING

ITEM	P/N	QTY	DESCRIPTION
40	68973	2	TOOL RETAINER PIN (USED ON BREAKERS WITH S/N-24D 14A00 AND BELOW) NOTE: ITEMS 35 & 37 ARE USED WITH THIS RETAINER PIN.
40A	73458	2	TOOL RETAINER PIN (USED ON BREAKERS WITH S/N-24D 14A01 AND ABOVE) NOTE: ITEMS 35 & 37 ARE NOT USED WITH THIS RETAINER PIN.
42	68711	2	GREASE NIPPLE
43	68712	1	PLUG
43A	69102	1	PLUG
KT	72338	1	TIE ROD KIT (INCL ONE EACH OF ITEMS 44, 45A, 46 & 47)
44	68974	4	TIE ROD
45A	71665	4	LOWER TIE ROD NUT MBX308
46	68976	4	TIE ROD WASHER
47	68977	4	UPPER TIE ROD NUT
48	68978	1	ACCUMULATOR COVER
49	68979	1	ACCUMULATOR BOWL
50	68980	1	DIAPHRAGM
51	68981	1	DIAPHRAGM SCREEN ASSY
52	68982	1	BACK-UP RING
53	68983	1	O-RING
54	68984	1	CHARGE VALVE
55	68985	1	CHARGE VALVE CAP
56	68986	1	O-RING
57	68987	1	PLUG
58	68988	12	CAPSCREW
59	68989	2	O-RING
60	68990	4	CAPSCREW
60A	72101	4	NORD LOCK WASHER
61	68991	4	HELICOIL
63	71667	1	TOOL BIT MBX308 CROSS CUT CHISEL
SEE PAGE 61 FOR ADDITIONAL TOOL BITS.			
KT	68996	1	SEAL KIT

MBX308 HOUSING PARTS

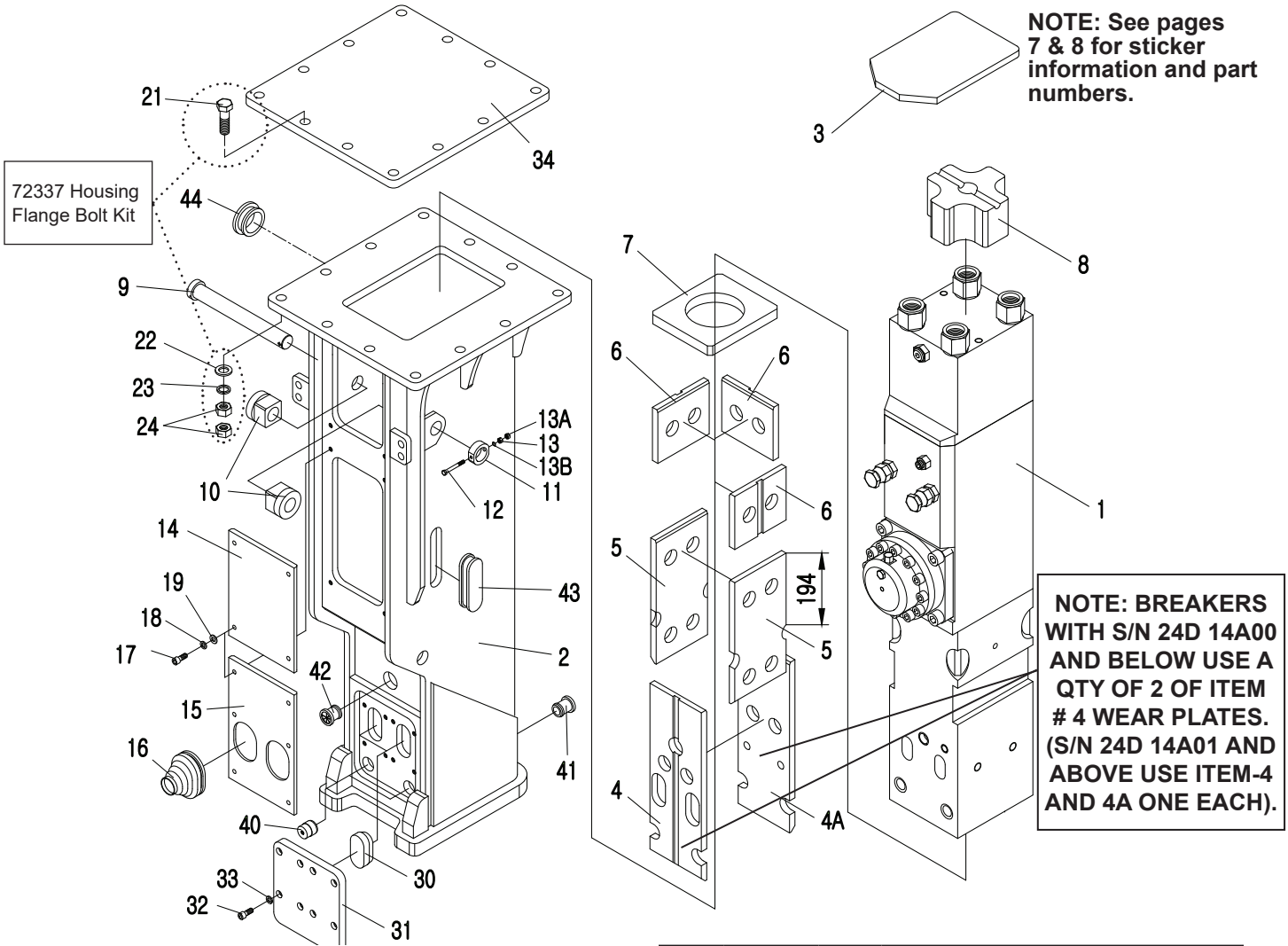

ITEM	P/N	QTY	DESCRIPTION
1	68997	1	POWER CELL
2	72297	1	HOUSING
3	68999	1	UPPER BUMPER SUPPORT
4	72284	1 / 2	WEAR PLATE (SEE NOTE ABOVE)
4A	73457	1	WEAR PLATE (SEE NOTE ABOVE)
5	72285	2	WEAR PLATE
6	69005	3	WEAR PLATE
7	72286	1	LOWER BUMPER
8	69007	1	UPPER BUMPER
9	69009	1	GUIDE PIN
10	69013	2	WEAR BUSHING
11	69014	1	STOP RING
12	69052	1	CAPSCREW
13	68733	1	NUT
13A	71635	1	NYLON NUT
13B	68738	1	SPRING WASHER
14	69054	1	UPPER WINDOW COVER
15	69055	1	LOWER WINDOW COVER

ITEM	P/N	QTY	DESCRIPTION
16	68923	2	RUBBER BOOT
17	68924	10	CAPSCREW
18	68925	10	LOCK WASHER
19	68926	10	WASHER
KT	72337	1	HOUSING FLANGE BOLT KIT (INCL 1 EA OF ITEMS 21 THRU 23 AND 2 EA OF ITEM 24)
21	72256	12	CAPSCREW
22	68741	12	WASHER
23	68742	12	LOCK WASHER
24	72257	24	NUT
30	69056	2	TOOL RETAINER PLUG
31	71674	1	TOOL PIN RETAINER PLATE
32	68746	8	CAPSCREW
33	68747	8	LOCK WASHER
40	71636	2	RUBBER PLUG
41	71650	4	RUBBER PLUG
42	71638	1	RUBBER PLUG
43	71651	2	RUBBER PLUG
44	82582	1	RUBBER PLUG

MBX358 POWER CELL ILLUSTRATION

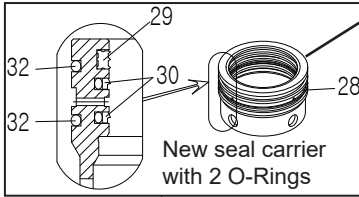

Seals for both old and new versions of seal retainer are included in seal kit.

New seal carrier with 2 O-Rings

NOTE: In May 2014 item 28 seal retainer changed. The two outer seal grooves widths changed and are now narrower. Tools with Serial # S/#30D 14 C55 & above only require 7A O-rings not the backup rings.

FOR ITEMS 69 AND 69A SEE PARTS LIST FOR CORRECT ITEM FOR YOUR SERIAL NUMBER

FOR THESE TWO ITEMS SEE 69A ON PARTS LIST. NOTE: THESE TWO PARTS ONLY USED WITH ITEM 69 NOT 69A

NOTE: Items 54, 57 & 58 changed in late May 2014. Breakers with serial # 30D 14C42 and above now use Accumulator bowl P/N-73594, Backup ring 73595 & O-Ring 73596. Older breakers use Accumulator bowl 69118, with Backup ring 68982 & O-Ring 68983. **Older breakers can also use the 73594 Accumulator Bowl but must use the backup ring and O-ring that go with it as shown above. If replacing the old accumulator bowl, the new bowl and seals must be ordered as 69118 is no-longer available.**

ITEMS 54, 57 & 58 SEE NOTE

MBX358 POWER CELL PARTS LIST

ITEM	P/N	QTY	DESCRIPTION
1	69061	1	MAIN ACCUMULATOR
2	69062	1	O-RING
3	69065	2	FLANGE ADAPTER
4	69067	2	BACK UP RING
4A	72102	2	O-RING
5	69068	2	O-RING
6	69069	8	CAPSCREW
7	68809	2	ADAPTER CAP
7A	68807	2	ADAPTER
8	68679	1	CHARGING VALVE
9	68680	1	CHARGING VALVE PLUG
10	68681	1	O-RING
11	69074	1	CYLINDER
12A	73476	1	PISTON
13	69076	4	PLUG
14	68687	2	DOWEL PIN
15	68991	8	HELICOIL
16	69077	8	HELICOIL
17	69078	1	BUFFER SEAL
18	69079	1	U-PACKING
19	69080	1	DUST SEAL
20	69081	5	O-RING
21	69082	2	TEFLON BUSHING
22	69083	1	TEFLON PLUG
23	69085	4	O-RING
24	69086	1	CYLINDER ADJUSTER
25	69087	2	ADJUSTER NUT
26	69088	1	O-RING
27	69089	1	BACK UP RING
28	69091	1	SEAL RETAINER
29	69092	1	GAS SEAL
30	69093	2	STEP SEAL
31	69094	3	BACK UP RING
32	69095	2	O-RING
33	69096	1	VALVE BODY
34A	73477	1	VALVE SLEEVE
35	69098	1	VALVE
36	69099	1	VALVE CAP
37	69100	1	HEX' PLUG
38	69101	1	PLUG
39	69102	2	PLUG
40	69103	3	O-RING
41	69104	1	O-RING
42	69105	1	BACK UP RING
43	69106	4	CAPSCREW
44	69107	8	CAPSCREW
45	69109	1	O-RING
46	69110	1	BACK UP RING

ITEM	P/N	QTY	DESCRIPTION
47	69111	3	O-RING
48	69112	1	O-RING
49	69113	2	O-RING
50	69114	1	VALVE ADJUSTER
51	69115	1	BACK UP RING
52	69116	3	O-RING
53	69117	1	ACCUMULATOR COVER
54	73594	1	ACCUM BOWL (SEE NOTE - POWER CELL ILLUSTRATION)
55	69119	1	DIAPHRAGM
56	68981	1	DIAPHRAGM SCREEN ASSY
57	73595	1	BACK UP RING (SEE NOTE - POWER CELL ILLUSTRATION)
57A	68982	1	BACK UP RING (SEE NOTE - POWER CELL ILLUSTRATION)
58	73596	1	O-RING (SEE NOTE - POWER CELL ILLUSTRATION)
58A	68983	1	O-RING (SEE NOTE - POWER CELL ILLUSTRATION)
59	68985	1	CHARGE VALVE CAP
60	68984	1	CHARGING VALVE
61	68986	1	O-RING
62	68987	1	PLUG
63	69120	12	CAPSCREW
64	68990	8	CAPSCREW
64A	72101	8	NORD LOCK WASHER
65A	72103	1	LOWER BODY
66	69122	1	TOOL STOP
67B	72104	1	LOWER BUSHING (LONG)
68	69124	2	RETAINER PIN
69	69125	2	TOOL RETAINER PIN (USED ON S/N-30D 14A00 AND BELOW) NOTE: ITEMS 68 & 74 ARE USED WITH THIS RETAINER PIN.
69A	73460	2	TOOL RETAINER PIN (USED ON S/N-30D 14A01 AND ABOVE) NOTE: ITEMS 68 & 74 ARE NOT USED WITH THIS RETAINER PIN.
70	69126	2	RETAINER PIN
71	68685	1	PLUG
71A	68712	3	PLUG
72	68711	2	GREASE NIPPLE
73	68972	2	SNAP RING
74	68970	2	RUBBER PLUG
75	68971	2	RUBBER PLUG
KT	72340	1	TIE ROD KIT (SEE EXPLODED VIEW)
76	69128	4	TIE ROD
77A	71654	4	LOWER TIE ROD NUT
78	69130	4	TIE ROD WASHER
79	69131	4	UPPER TIE ROD NUT
81	72108	1	TOOL BIT (CROSS CUT CHISEL)
SEE PAGE 61 FOR ADDITIONAL TOOL BITS.			
KT	69136	1	SEAL KIT

MBX358 HOUSING PARTS

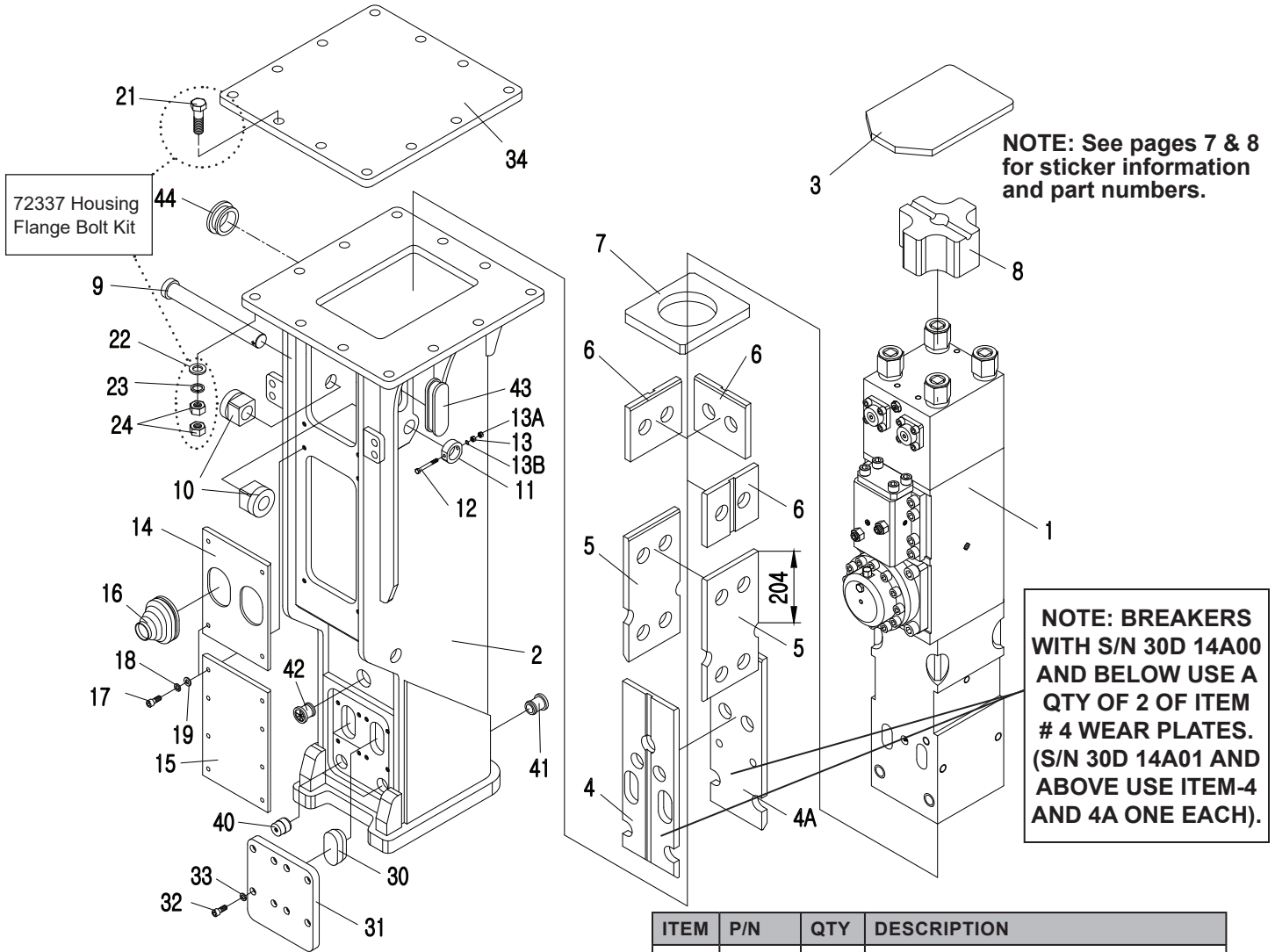

NOTE: See pages 7 & 8 for sticker information and part numbers.

NOTE: BREAKERS WITH S/N 30D 14A00 AND BELOW USE A QTY OF 2 OF ITEM # 4 WEAR PLATES. (S/N 30D 14A01 AND ABOVE USE ITEM-4 AND 4A ONE EACH).

ITEM	P/N	QTY	DESCRIPTION
1	69137	1	POWER CELL
2	69138	1	HOUSING
3	69139	1	UPPER BUMPER SUPPORT
4	69140	1 / 2	WEAR PLATE (SEE NOTE ABOVE)
4A	73459	1	WEAR PLATE (SEE NOTE ABOVE)
5	69141	2	WEAR PLATE (LR)
6	69142	3	WEAR PLATE (U)
7	69143	1	LOWER BUMPER
8	69145	1	UPPER BUMPER
9	69146	1	GUIDE PIN
10	69013	2	WEAR BUSHING
11	69014	1	STOP RING
12	69052	1	CAPSCREW
13	68733	1	NUT
13A	71635	1	NYLON NUT
13B	68738	1	LOCK WASHER
14	69151	1	UPPER WINDOW COVER
15	69152	1	LOWER WINDOW COVER

ITEM	P/N	QTY	DESCRIPTION
16	68923	2	RUBBER BOOT
17	68924	12	CAPSCREW
18	68925	12	LOCK WASHER
19	68926	12	WASHER
KT	72337	1	HOUSING FLANGE BOLT KIT (INCL ONE EA OF ITEMS 21 THRU 23 & TWO EA OF ITEM 24)
21	72256	12	CAPSCREW
22	68741	12	WASHER
23	68742	12	LOCK WASHER
24	72257	24	NUT
30	69056	2	TOOL RETAINER PLUG
31	69154	1	TOOL PIN RETAINER COVER PLATE
32	68746	8	CAPSCREW
33	68747	8	LOCK WASHER
40	71636	2	RUBBER PLUG
41	72248	4	RUBBER PLUG
42	71638	1	RUBBER PLUG
43	71651	2	RUBBER PLUG
44	82582	1	RUBBER PLUG

MBX408 POWER CELL ILLUSTRATION

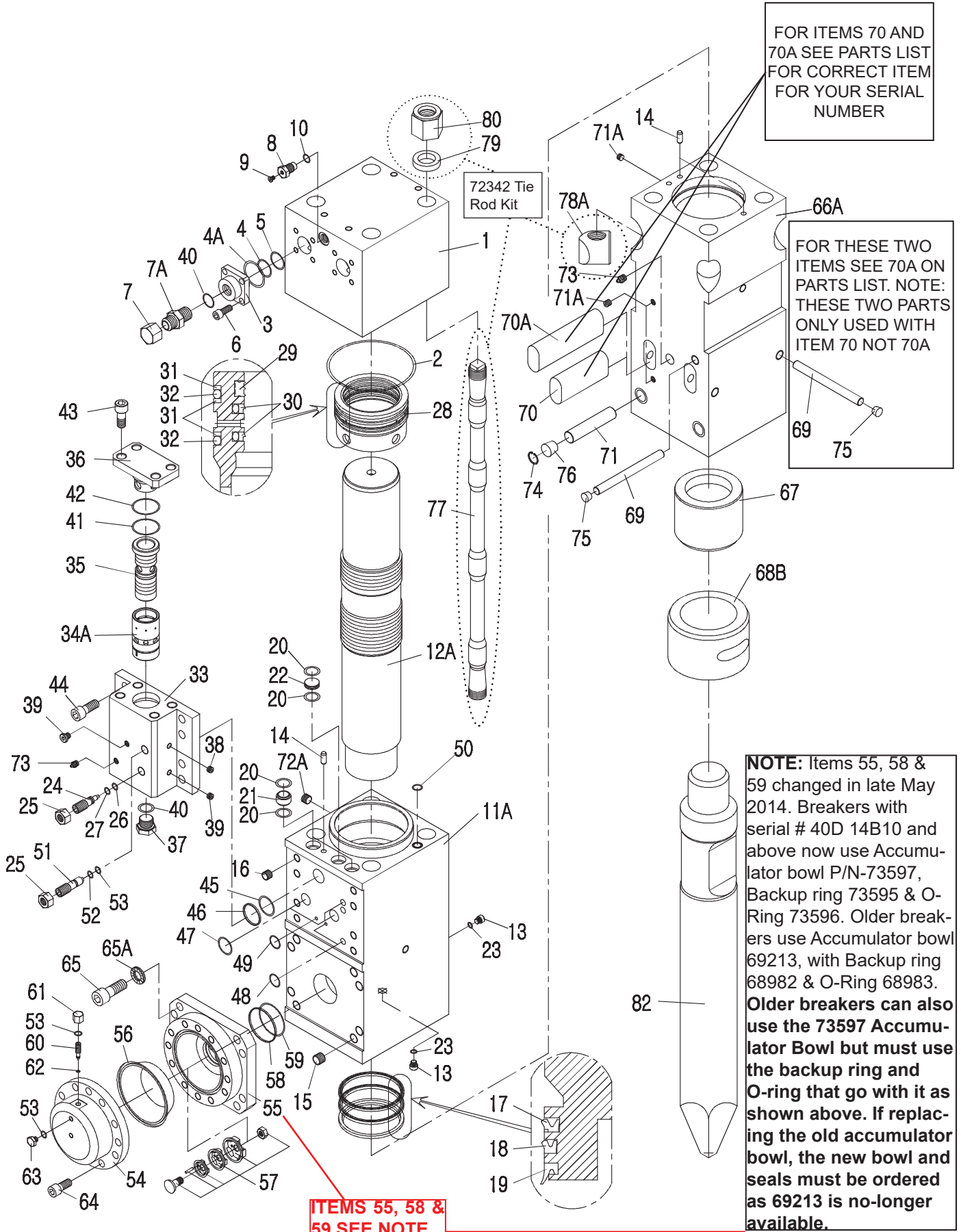

MBX408 POWER CELL PARTS LIST

ITEM	P/N	QTY	DESCRIPTION
1	69160	1	MAIN ACCUMULATOR
2	69161	1	O-RING
3	69162	2	FLANGE ADAPTER
4	69163	2	BACK UP RING
4A	72109	2	O-RING
5	69164	2	O-RING
6	69069	8	CAPSCREW
7	69165	2	PLUG
7A	72110	2	ADAPTER
8	68679	1	CHARGING VALVE
9	68680	1	PLUG
10	68681	1	O-RING
11A	73471	1	CYLINDER
12A	73478	1	PISTON
13	69076	2	PLUG
14	69168	3	DOWEL PIN
15	68991	8	HELICOIL
16	69169	8	HELICOIL
17	69170	1	SEAL BUFFER
18	69174	1	SEAL U-CUP
19	69175	1	SEAL DUST
20	69176	6	O-RING
21	69177	2	TEFLON BUSHING
22	69178	1	TEFLON PLUG
23	69179	2	O-RING
24	69086	1	CYLINDER ADJUSTER
25	69087	2	ADJUSTER NUT
26	69088	1	O-RING
27	69089	1	BACK UP RING
28	69180	1	SEAL CARRIER
29	69181	1	GAS SEAL
30	69412	2	STEP SEAL
31	69183	3	BACK UP RING
32	69413	2	O-RING
33	69185	1	VALVE BODY
34A	73479	1	VALVE SLEEVE
35	69189	1	VALVE
36	69193	1	VALVE CAP
37	69194	1	PLUG
38	69101	1	PLUG
39	69102	2	PLUG
40	69199	3	O-RING
41	69200	1	O-RING
42	69202	1	BACK UP RING
43	69106	4	CAPSCREW

ITEM	P/N	QTY	DESCRIPTION
44	69107	8	CAPSCREW
45	69414	1	O-RING
46	69205	1	BACK UP RING
47	69206	3	O-RING
48	69207	2	O-RING
49	69208	1	O-RING
50	69209	2	O-RING
51	69210	1	VALVE ADJUSTER
52	69211	1	BACK UP RING
53	68989	3	O-RING
54	69212	1	ACCUMULATOR COVER
55	73597	1	ACCUM BOWL (SEE NOTE - POWER CELL ILLUSTRATION)
56	69214	1	DIAPHRAGM
57	68981	1	DIAPHRAGM SCREEN ASSY
58	73595	1	BACK UP RING (SEE NOTE - POWER CELL ILLUSTRATION)
58A	68982		BACK UP RING (SEE NOTE - POWER CELL ILLUSTRATION)
59	73596	1	O-RING (SEE NOTE - POWER CELL ILLUSTRATION)
59A	68983		O-RING (SEE NOTE - POWER CELL ILLUSTRATION)
60	68984	1	CHARGING VALVE
61	68985	1	CHARGE VALVE CAP
62	68986	1	O-RING
63	68987	1	PLUG
64	69215	16	CAPSCREW
65	68990	8	CAPSCREW
65A	72101	8	NORD LOCK WASHER
66A	72111	1	LOWER BODY
67	69217	1	TOOL STOP
68B	72112	1	LOWER BUSHING
69	69219	2	RETAINER PIN
70	69220	2	TOOL RETAINER PIN (USED ON BREAKERS WITH S/N-40D 14B00 AND BELOW) NOTE: ITEMS 69 & 75 ARE USED WITH THIS RETAINER PIN.

ITEM	P/N	QTY	DESCRIPTION
70A	73462	2	TOOL RETAINER PIN (USED ON BREAKERS WITH S/N-40D 14B01 AND ABOVE) NOTE: ITEMS 69 & 75 ARE NOT USED WITH THIS RETAINER PIN.
71	69415	2	RETAINER PIN
71A	68712	3	PLUG
72A	68685	1	PLUG
73	68711	2	GREASE NIPPLE
74	68972	2	SNAP RING
75	68970	2	RUBBER PLUG
76	68971	2	RUBBER PLUG
KT	72342	1	TIE ROD KIT (SEE EXPLODED VIEW)
77	69222	4	TIE ROD
78A	72113	4	LOWER TIE ROD NUT
79	69225	4	TIE ROD WASHER
80	69226	4	UPPER TIE ROD NUT
82	72117	1	TOOL BIT (CROSS CUT CHISEL)
SEE PAGE 61 FOR ADDITIONAL TOOL BITS.			
KT	69231	1	SEAL KIT

MBX408 HOUSING PARTS

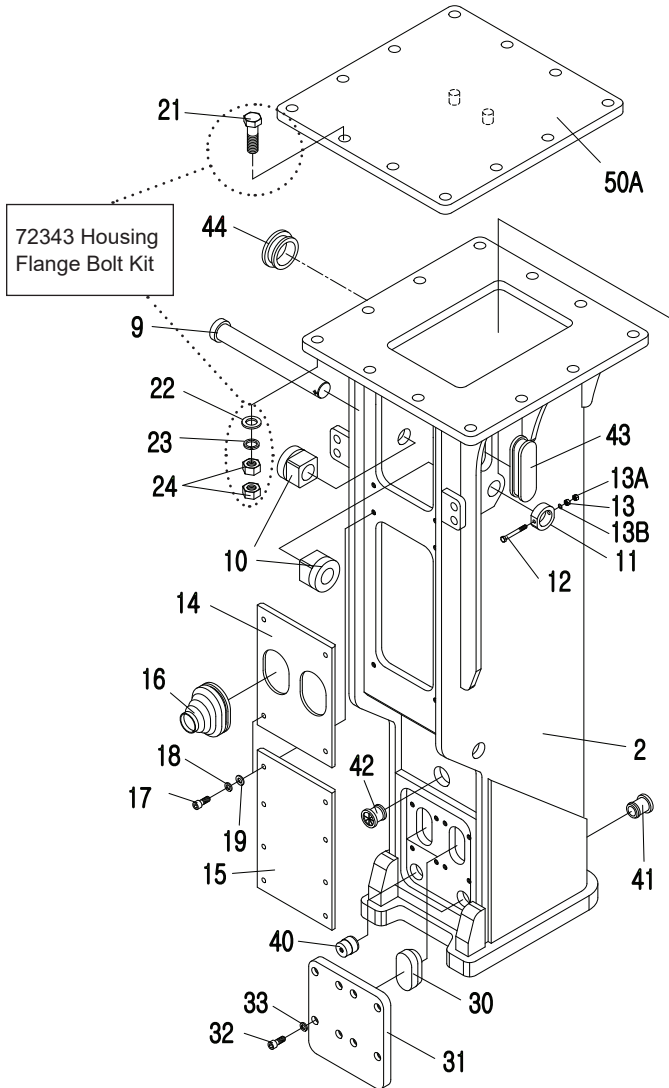

Note: Changes were made in April 2012 of the upper bumper and cover plate, see pages 30 & 31 for more information.

NOTE: See pages 7 & 8 for sticker information and part numbers.

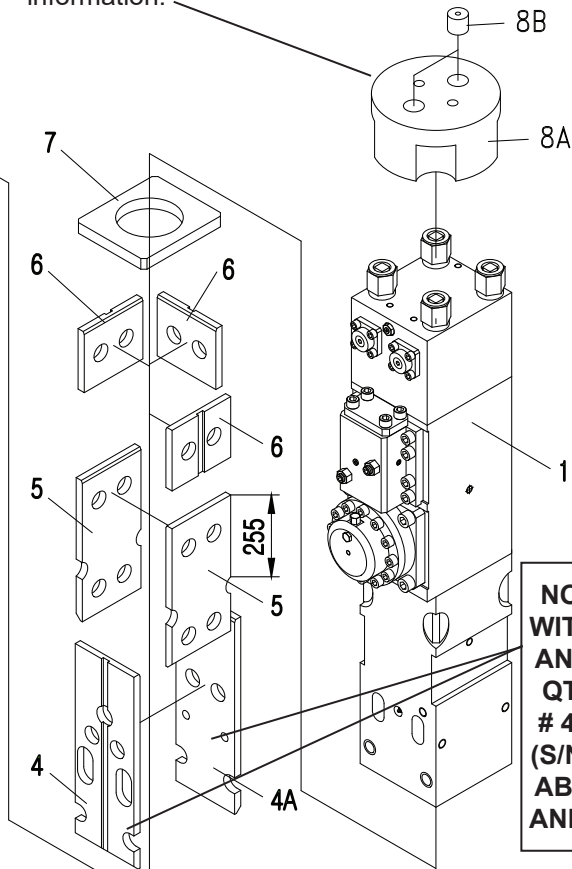

NOTE: BREAKERS WITH S/N 40D 14B00 AND BELOW USE A QTY OF 2 OF ITEM # 4 WEAR PLATES. (S/N 40D 14B01 AND ABOVE USE ITEM-4 AND 4A ONE EACH).

ITEM	P/N	QTY	DESCRIPTION
1	69232	1	POWER CELL
2	69233	1	HOUSING
3	69418	1	UPPER BUMPER SUPPORT
4	69256	1 / 2	WEAR PLATE (SEE NOTE ABOVE)
4A	73461	1	WEAR PLATE (SEE NOTE ABOVE)
5	69257	2	WEAR PLATE (LR)
6	69258	3	WEAR PLATE(U)
7	69259	1	LOWER BUMPER
8A	72984	1	UPPER BUMPER
8B	72985	2	UPPER BUMPER PLUG
9	69261	1	GUIDE PIN
10	69262	2	WEAR BUSHING
11	69263	1	STOP RING
12	69264	1	CAPSCREW
13	68733	1	NUT
13A	71635	1	NYLON NUT
13B	68738	1	LOCK WASHER
14	69266	1	UPPER WINDOW COVER

ITEM	P/N	QTY	DESCRIPTION
15	69267	1	LOWER WINDOW COVER
16	69268	2	RUBBER BOOT
17	68924	12	CAPSCREW
18	68925	12	LOCK WASHER
19	68926	12	WASHER
KT	72343	1	HOUSING FLANGE BOLT KIT (INCL ONE EA OF ITEMS 21 THRU 23 & TWO EA OF ITEM 24)
21	69269	12	CAPSCREW
22	69270	12	WASHER
23	69271	12	LOCK WASHER
24	69272	24	NYLON NUT
30	69273	2	TOOL RETAINER PLUG
31	69274	1	TOOL PIN RETAINER COVER
32	68746	8	CAPSCREW
33	68747	8	LOCK WASHER
40	71636	2	RUBBER PLUG
41	76497	4	RUBBER PLUG
42	72119	1	RUBBER PLUG
43	82588	2	RUBBER PLUG
44	82586	1	RUBBER PLUG

MBX458 POWER CELL ILLUSTRATION

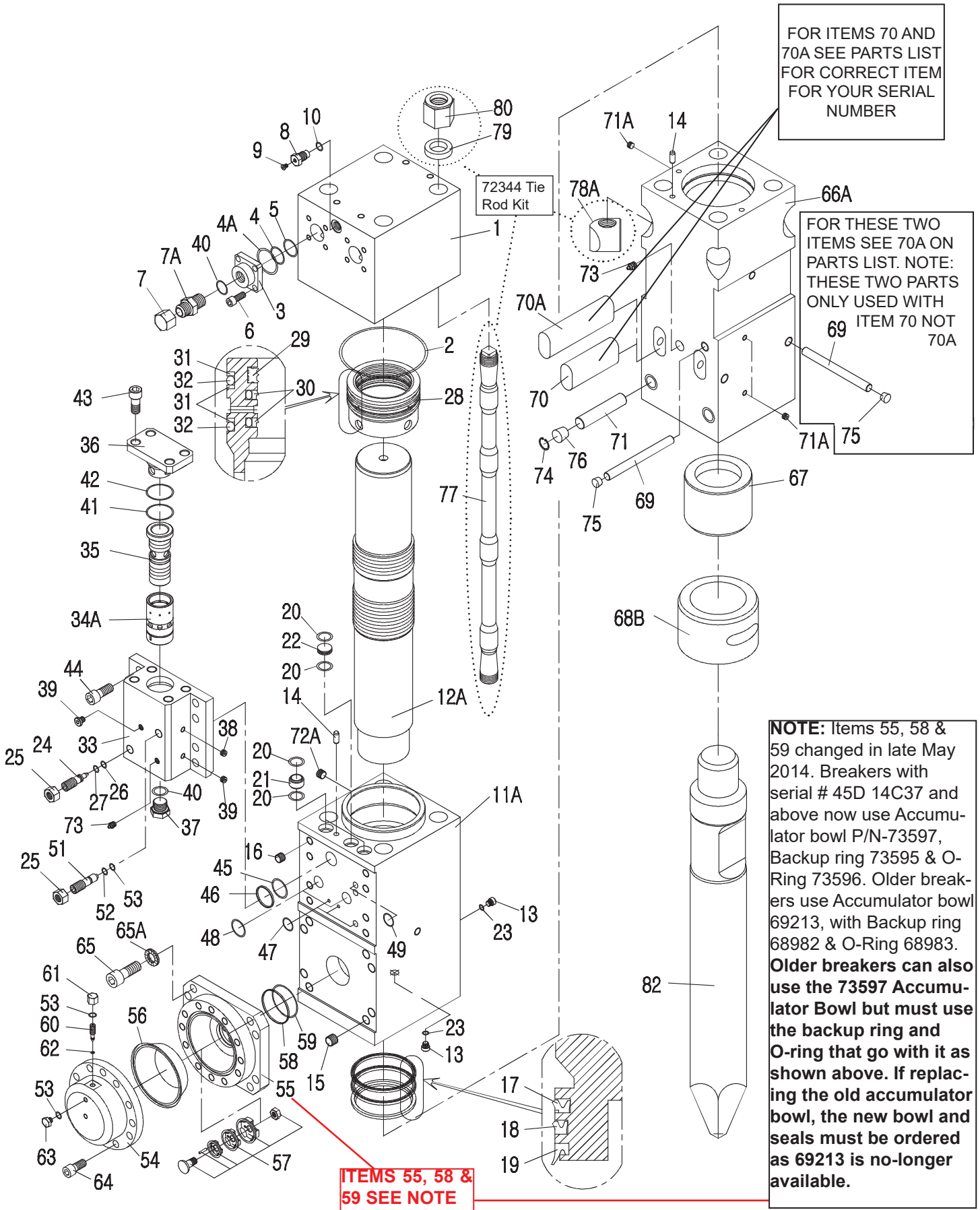

MBX458 POWER CELL PARTS LIST

ITEM	P/N	QTY	DESCRIPTION	ITEM	P/N	QTY	DESCRIPTION	ITEM	P/N	QTY	DESCRIPTION	
1	72120	1	MAIN ACCUMULATOR	43	72142	4	CAPSCREW	70A	73462	2	TOOL RETAINER PIN (USED ON BREAKERS WITH S/N-45D 14A07 AND ABOVE) NOTE: ITEMS 69 & 75 ARE NOT USED WITH THIS RETAINER PIN.	
2	72121	1	O-RING	44	69107	8	CAPSCREW					
3	69162	2	FLANGE ADAPTER	45	72143	1	O-RING					
4	69163	2	BACK UP RING	46	72144	1	BACK UP RING					
4A	72109	2	O-RING	47	72145	3	O-RING					
5	69164	2	O-RING	48	72146	2	O-RING					
6	69069	8	CAPSCREW	49	72147	1	O-RING	71	72151	2		RETAINER PIN
7	69165	2	PLUG	51	69210	1	VALVE ADJUSTER	71A	68712	3		PLUG
7A	72110	2	ADAPTER	52	69211	1	BACK UP RING	72A	68685	1		PLUG
8	68679	1	CHARGING VALVE	53	68989	3	O-RING	73	68711	2		GREASE NIPPLE
9	68680	1	PLUG	54	69212	1	ACCUMULATOR COVER	74	72152	2	SNAP RING	
10	68681	1	O-RING	55	73597	1	ACCUM BOWL (SEE NOTE- POWER CELL ILLUSTRATION)	75	68970	2	RUBBER PLUG	
11A	73472	1	CYLINDER	56	69214	1	DIAPHRAGM	76	72153	2	RUBBER PLUG	
12A	73480	1	PISTON	57	68981	1	DIAPHRAGM SCREEN ASSY	KT	72344	1	TIE ROD KIT (SEE EXPLODED VIEW)	
13	69076	2	PLUG	58	73595	1	BACK UP RING (SEE NOTE - POWER CELL ILLUSTRATION)	77	72154	4	TIE ROD	
14	69168	2	DOWEL PIN	58A	68982		BACK UP RING (SEE NOTE - POWER CELL ILLUSTRATION)	78A	72155	4	LOWER TIE ROD NUT	
15	68991	8	HELICOIL	59	73596	1	O-RING (SEE NOTE - POWER CELL ILLUSTRATION)	79	72156	4	TIE ROD WASHER	
16	69169	8	HELICOIL	59A	68983		O-RING (SEE NOTE - POWER CELL ILLUSTRATION)	80	72157	4	UPPER TIE ROD NUT	
17	72124	1	SEAL BUFFER	60	68984	1	CHARGING VALVE	82	72165	1	TOOL BIT (CROSS CUT CHISEL)	
18	72125	1	SEAL U-CUP	61	68985	1	CHARGE VALVE CAP	SEE PAGE 61 FOR ADDITIONAL TOOL BITS.				
19	72126	1	SEAL DUST	62	68986	1	O-RING					KT
20	72127	6	O-RING	63	68987	1	PLUG					
21	72128	2	TEFLON BUSHING	64	69215	16	CAPSCREW					
22	72129	1	TEFLON PLUG	65	68990	8	CAPSCREW					
23	72130	2	O-RING	65A	72101	8	NORD LOCK WASHER					
24	69086	1	CYLINDER ADJUSTER	66A	72148	1	LOWER BODY					
25	69087	2	ADJUSTER NUT	67	72149	1	TOOL STOP					
26	69088	1	O-RING	68B	72150	1	LOWER BUSHING					
27	69089	1	BACK UP RING	69	69219	2	RETAINER PIN					
28	72131	1	SEAL CARRIER	70	69220	2	TOOL RETAINER PIN (USED ON BREAKERS WITH S/N-45D 14A06 AND BELOW) NOTE: ITEMS 69 & 75 ARE USED WITH THIS RETAINER PIN.					
29	72132	1	GAS SEAL									
30	72133	2	STEP SEAL									
31	72134	3	BACK UP RING									
32	72135	2	O-RING									
33	72136	1	VALVE BODY									
34A	73481	1	VALVE SLEEVE									
35	72138	1	VALVE									
36	72139	1	VALVE CAP									
37	69194	1	PLUG									
38	69101	1	PLUG									
39	69102	2	PLUG									
40	69199	3	O-RING									
41	72140	1	O-RING									
42	72141	1	BACK UP RING									

MBX458 HOUSING PARTS

Note: Changes were made in April 2012 of the upper bumper and cover plate, see pages 30 & 31 for more information.

NOTE: See pages 7 & 8 for sticker information and part numbers.

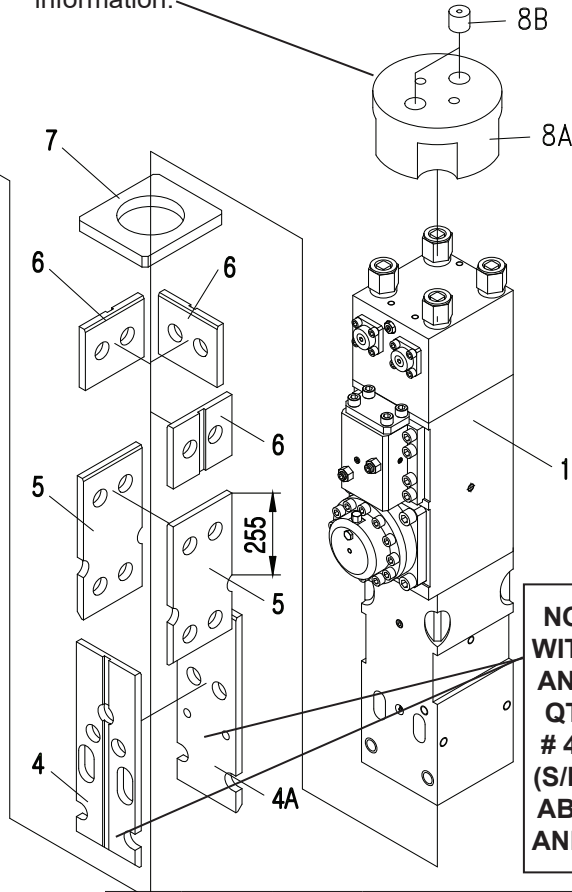
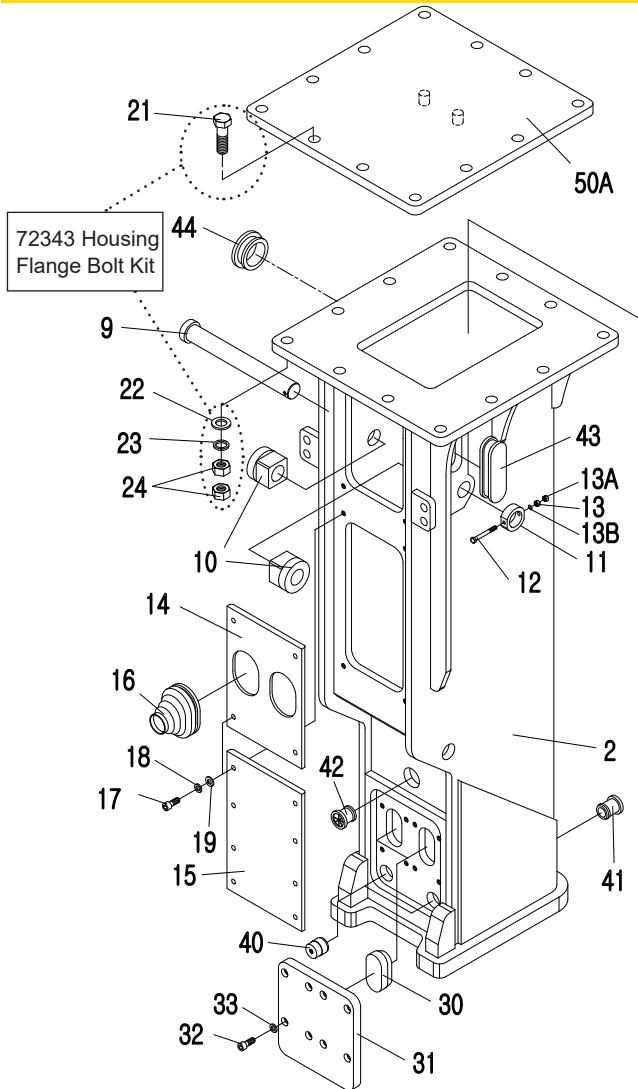

NOTE: BREAKERS WITH S/N 45D 14A06 AND BELOW USE A QTY OF 2 OF ITEM # 4 WEAR PLATES. (S/N 45D 14A07 AND ABOVE USE ITEM-4 AND 4A ONE EACH).

ITEM	P/N	QTY	DESCRIPTION
1	72167	1	POWER CELL
2	72170	1	HOUSING
3	69418	1	UPPER BUMPER SUPPORT
4	69256	1 / 2	WEAR PLATE (SEE NOTE ABOVE)
4A	73461	1	WEAR PLATE (SEE NOTE ABOVE)
5	69257	2	WEAR PLATE (LR)
6	69258	3	WEAR PLATE (U)
7	72168	1	LOWER BUMPER
8A	72984	1	UPPER BUMPER
8B	72985	2	UPPER BUMPER PLUG
9	69261	1	GUIDE PIN
10	69262	2	WEAR BUSHING
11	69263	1	STOP RING
12	69264	1	CAPSCREW
13	68733	1	NUT
13A	71635	1	NYLON NUT
13B	68738	1	LOCK WASHER
14	69266	1	UPPER WINDOW COVER

ITEM	P/N	QTY	DESCRIPTION
15	69267	1	LOWER WINDOW COVER
16	69268	2	RUBBER BOOT
17	68924	12	CAPSCREW
18	68925	12	LOCK WASHER
19	68926	12	WASHER
KT	72343	1	HOUSING FLANGE BOLT KIT (INCL ONE EA OF ITEMS 21 THRU 23 & TWO EA OF ITEM 24)
21	69269	12	CAPSCREW
22	69270	12	WASHER
23	69271	12	LOCK WASHER
24	69272	24	NYLON NUT
30	69273	2	TOOL RETAINER PLUG
31	72169	1	TOOL PIN RETAINER PLATE
32	68746	8	CAPSCREW
33	68747	8	LOCK WASHER
40	72171	2	RUBBER PLUG
41	76497	4	RUBBER PLUG
42	72119	1	RUBBER PLUG
43	82588	2	RUBBER PLUG
44	82586	1	RUBBER PLUG

MBX608 POWER CELL ILLUSTRATION

NOTE: If your Breaker has S/N-50B, 50C the Cylinder item 6 and Lower Body item 32A are an older version, S/N-50D and above are the newer version parts. Please see page 32 and the parts list before ordering to make sure the correct parts are ordered.

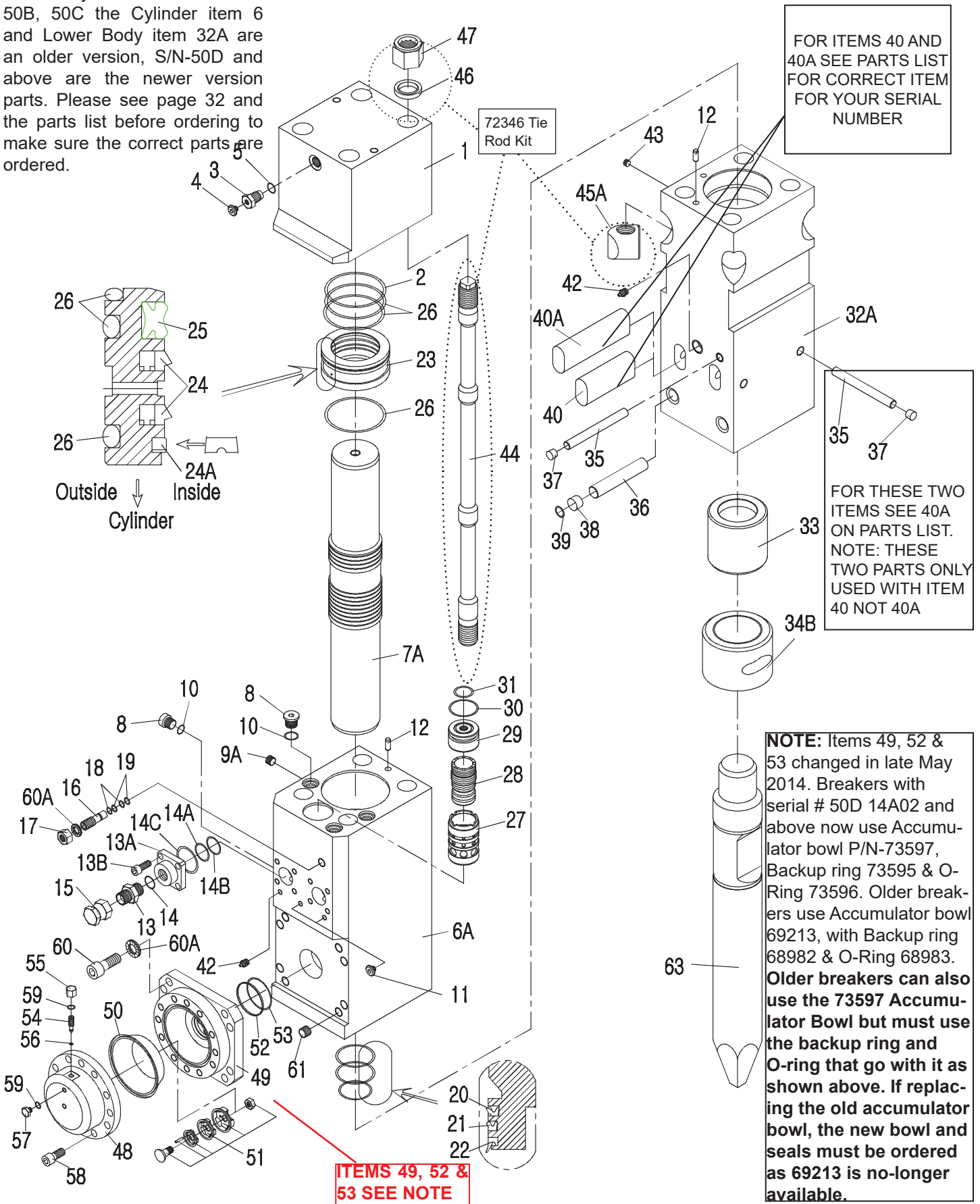

MBX608 POWER CELL PARTS LIST

ITEM	P/N	QTY	DESCRIPTION
1	72172	1	MAIN ACCUMULATOR
2	72173	1	O-RING
3	68679	1	CHARGING VALVE
4	68680	1	PLUG
5	68681	1	O-RING
6A	73473	1	CYLINDER (NEWER VERSION) USED ON S/N-50D AND ABOVE. SEE PAGE 32 FOR MORE DETAILS.
6	76769	1	CYLINDER (OLDER VERSION) USED ON S/N-50B-50C AND BELOW. SEE PAGE 32 FOR MORE DETAILS.
7A	73482	1	PISTON
8	72176	4	CAPSCREW
9A	68685	1	PLUG
10	72177	4	O-RING
11	69102	2	PLUG
12	69168	3	DOWEL PIN
13	72110	2	ADAPTER
13A	69162	2	FLANGE ADAPTER
13B	69069	8	CAPSCREW
14	69199	2	O-RING
14A	69163	2	BACK UP RING
14B	72109	2	O-RING
14C	69164	2	O-RING
15	69165	2	PLUG
16	72178	1	CYLINDER ADJUSTER
17	72179	1	ADJUSTER NUT
18	72180	2	O-RING
19	72181	2	BACK UP RING
20	72182	1	BUFFER SEAL
21	72183	1	U-PACKING
22	72184	1	DUST SEAL
23	72185	1	SEAL RETAINER
24	72186	2	STEP SEAL
24A	72252	1	BUFFER RING
25	72187	1	GAS SEAL
26	72188	3	O-RING
27	72189	1	VALVE SLEEVE
28	72190	1	VALVE
29	72191	1	VALVE CAP
30	72192	1	O-RING
31	72193	1	O-RING
32B	72194	1	LOWER BODY (NEWER VERSION) USED ON S/N-50D AND ABOVE. SEE PAGE 32 FOR MORE DETAILS.
32A	76770	1	LOWER BODY (OLDER VERSION) USED ON S/N-50B-50C AND BELOW. SEE PAGE 32 FOR MORE DETAILS.
33	72195	1	TOOL STOP

ITEM	P/N	QTY	DESCRIPTION
34B	72196	1	LOWER BUSHING
35	72197	2	RETAINER PIN
36	72198	2	RETAINER PIN
37	72199	2	RUBBER PLUG
38	72153	2	RUBBER PLUG
39	72152	2	SNAP RING
40	72213	2	TOOL RETAINER PIN (USED ON BREAKERS WITH S/N-50D 13L45 AND BELOW) NOTE: ITEMS 35 & 37 ARE USED WITH THIS RETAINER PIN.
40A	73466	2	TOOL RETAINER PIN (USED ON BREAKERS WITH S/N-50D 13L46 AND ABOVE) NOTE: ITEMS 35 & 37 ARE NOT USED WITH THIS RETAINER PIN.
42	68711	2	GREASE NIPPLE
43	68712	3	PLUG
KT	72346	1	TIE ROD KIT (INCL ONE EACH OF ITEMS 44, 45A, 46 & 47)
44	72200	4	TIE ROD
45A	72201	4	LOWER TIE ROD NUT
46	72202	4	TIE ROD WASHER
47	72203	4	UPPER TIE ROD NUT
48	69212	1	ACCUMULATOR COVER
49	73597	1	ACCU BOWL (SEE NOTE POWER CELL ILLUSTRATION)
50	69214	1	DIAPHRAGM
51	68981	1	DIAPHRAGM SCREEN ASSY
52	73595	1	BACK UP RING (SEE NOTE POWER CELL ILLUSTRATION)
52A	68982		BACK UP RING (SEE NOTE POWER CELL ILLUSTRATION)
53	73596	1	O-RING (SEE NOTE POWER CELL ILLUSTRATION)
53A	68983		O-RING (SEE NOTE POWER CELL ILLUSTRATION)
54	68984	1	CHARGE VALVE
55	68985	1	CHARGE VALVE CAP
56	68986	1	O-RING
57	68987	1	PLUG
58	69215	16	CAPSCREW
59	68989	2	O-RING
60	68990	8	CAPSCREW
60A	72101	9	NORD LOCK WASHER
61	68991	8	HELICOIL
63	72211	1	TOOL BIT (CROSS CUT CHISEL)
SEE PAGE 61 FOR ADDITIONAL TOOL BITS.			
KT	72212	1	SEAL KIT

MBX608 HOUSING PARTS

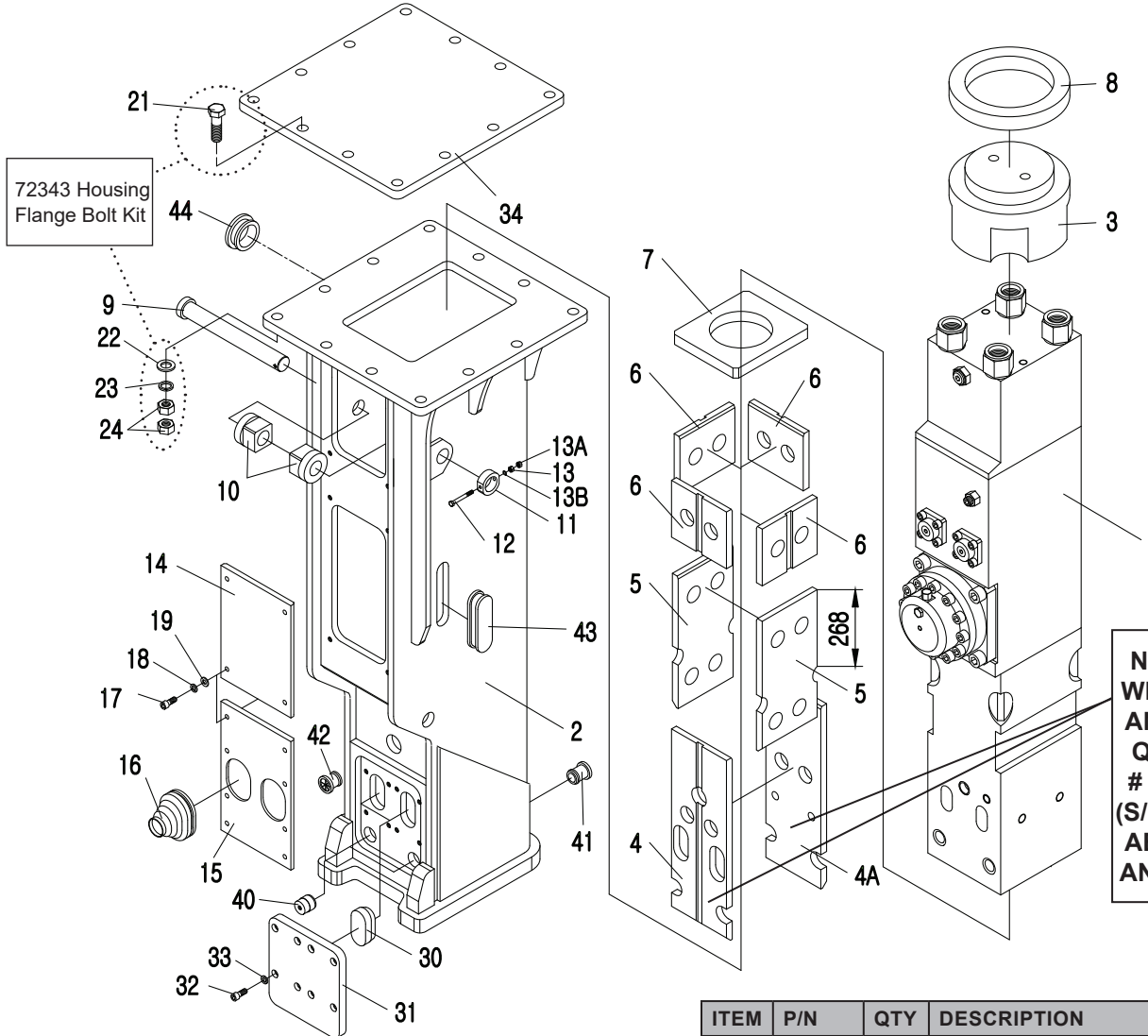

NOTE: See pages 7 & 8 for sticker information and part numbers.

NOTE: BREAKERS WITH S/N 50D 13L45 AND BELOW USE A QTY OF 2 OF ITEM # 4 WEAR PLATES. (S/N 450D 13L46 AND ABOVE USE ITEM-4 AND 4A ONE EACH).

ITEM	P/N	QTY	DESCRIPTION
1	72214	1	POWER CELL
2	72232	1	HOUSING
3	72233	1	UPPER BUMPER
4	72223	1 / 2	WEAR PLATE (SEE NOTE ABOVE)
4A	73465	1	WEAR PLATE (SEE NOTE ABOVE)
5	72224	2	WEAR PLATE (LR)
6	69258	4	WEAR PLATE (U)
7	72225	1	LOWER BUMPER
8	72226	1	UPPER BUFFER
9	72216	1	GUIDE PIN
10	72217	2	WEAR BUSHING
11	72218	1	STOP RING
12	72219	1	CAPSCREW
13	68733	1	NUT
13A	71635	1	NYLON NUT
13B	68738	1	LOCK WASHER
14	72220	1	UPPER WINDOW COVER
15	72221	1	LOWER WINDOW COVER

ITEM	P/N	QTY	DESCRIPTION
16	69268	2	RUBBER BOOT
17	72222	12	CAPSCREW
18	68925	12	LOCK WASHER
19	68926	12	WASHER
KT	72343	1	HOUSING FLANGE BOLT KIT (INCL ONE EA OF ITEMS 21 THRU 23 & TWO EA OF ITEM 24)
21	69269	12	CAPSCREW
22	69270	12	WASHER
23	69271	12	LOCK WASHER
24	69272	24	NYLON NUT
30	72227	2	TOOL RETAINER PLUG
31	72228	1	TOOL PIN RETAINER PLATE
32	72229	8	CAPSCREW
33	72230	8	LOCK WASHER
40	72234	2	RUBBER PLUG
41	72235	4	RUBBER PLUG
42	72236	1	RUBBER PLUG
43	72237	2	RUBBER PLUG
44	82587	1	RUBBER PLUG

TOOL BITS

MBX138		
71631	1	TOOL BIT MBX138 (CROSS CUT CHISEL)
71634	1	TOOL BIT MBX138 (MOIL)
71633	1	TOOL BIT MBX138 (BLUNT)
71630	1	TOOL BIT MBX138 (CONICAL)
71632	1	TOOL BIT MBX138 (LINE CUT CHISEL)
MBX208		
71645	1	TOOL BIT MBX208 (CROSS CUT CHISEL)
71648	1	TOOL BIT MBX208 (MOIL)
71647	1	TOOL BIT MBX208 (BLUNT)
71644	1	TOOL BIT MBX208 (CONICAL)
71646	1	TOOL BIT MBX208 (LINE CUT CHISEL)
MBX258		
71656	1	TOOL BIT MBX258 (CROSS CUT CHISEL)
71659	1	TOOL BIT MBX258 (MOIL)
71658	1	TOOL BIT MBX258 (BLUNT)
71655	1	TOOL BIT MBX258 (CONICAL)
71657	1	TOOL BIT MBX258 (LINE CUT CHISEL)
MBX308		
71667	1	TOOL BIT MBX308 (CROSS CUT CHISEL)
71670	1	TOOL BIT MBX308 (MOIL)
71669	1	TOOL BIT MBX308 (BLUNT)
71666	1	TOOL BIT MBX308 (CONICAL)
71668	1	TOOL BIT MBX308 (LINE CUT CHISEL)

MBX358		
72108	1	TOOL BIT MBX358 (CROSS CUT CHISEL)
72107	1	TOOL BIT MBX358 (MOIL)
72105	1	TOOL BIT MBX358 (BLUNT)
72106	1	TOOL BIT MBX358 (CONICAL)
72249	1	TOOL BIT MBX358 (LINE CUT CHISEL)
MBX408		
72117	1	TOOL BIT MBX408 (CROSS CUT CHISEL)
72116	1	TOOL BIT MBX408 (MOIL)
72114	1	TOOL BIT MBX408 (BLUNT)
72115	1	TOOL BIT MBX408 (CONICAL)
72250	1	TOOL BIT MBX408 (LINE CUT CHISEL)
MBX458		
72165	1	TOOL BIT MBX458 (CROSS CUT CHISEL)
72164	1	TOOL BIT MBX458 (MOIL)
72162	1	TOOL BIT MBX458 (BLUNT)
72163	1	TOOL BIT MBX458 (CONICAL)
72251	1	TOOL BIT MBX458 (LINE CUT CHISEL)
MBX608		
72211	1	TOOL BIT MBX608 (CROSS CUT CHISEL)
72210	1	TOOL BIT MBX608 (MOIL)
72208	1	TOOL BIT MBX608 (BLUNT)
72209	1	TOOL BIT MBX608 (CONICAL)
72253	1	TOOL BIT MBX608 (LINE CUT CHISEL)

STANLEY®

STANLEY
3810 SE Naef Road
Milwaukie, Oregon 97267 USA
(800) 972-2647 / Fax (503) 652-1780