



**EXCAVATOR &
WHEEL LOADER
ATTACHMENTS**

**Selection,
Innovation,
Performance**

Your One-Stop Shop
for Hydraulic Tools
and Attachments



STANLEY
Infrastructure

INDUSTRIAL TOOLS & ATTACHMENTS

 **PALADIN** **STANLEY** **LABOUNTY**  **PENGGO**

YOUR "ONE-STOP SHOP"

FOR HYDRAULIC TOOLS AND ATTACHMENTS



Paladin is the one-stop-shop for quality, productive and powerful attachment tools.

In addition to the extensive independent Paladin dealer network, Paladin manufactures construction equipment attachments for companies such as Caterpillar, Komatsu and John Deere to sell under their respective trademarks. Contact us today to inquire as to our manufacturing services for your construction equipment attachments.

MANUFACTURING FACILITIES

Dexter Facility

2800 Zeeb Road
Dexter, MI, 48130

Surrey Facility

19490 92nd Avenue
Surrey, B.C. Canada V4N 4G7

Akron Facility

820 Glaser Parkway
Akron, OH, 44306

Milwaukie Facility

3810 SE Naef Road
Milwaukie, OR 97267

Delhi Facility

503 Gay Street
Delhi, IA, 52223

Two Harbors Facility

1538 Hwy 2
Two Harbors, MN 55616

Ooltewah Facility

8822 Apison Pike
Ooltewah, TN, 37363

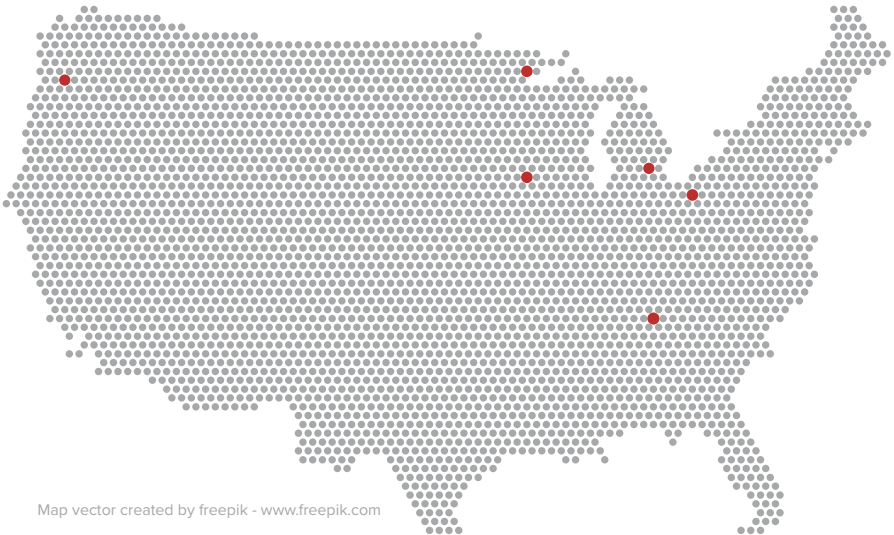

Map vector created by freepik - www.freepik.com



CustomWorks is a dynamic solutions provider, specializing in equipment modification when standard machines won't meet the performance requirements. Offering a broad range of products and services, a dedicated CustomWorks crew will engineer, manufacture and install a custom solution tailored to the application.

With four convenient locations, CustomWorks can modify equipment needing light enhancements or complex conversions not available through the OEM. After a rigorous inspection process, the machines will ship turnkey direct to the dealer yard or end user. The CustomWorks solution creates versatility so machines can be used in a wider range of applications across more markets.

Light Enhancements

Pre-Delivery Inspections Pattern Control Changer
➤ PDI and PDI PLUS Proportional Joystick Control Beacon/Strobe Decals
Block Heaters QC Attachments
Hydraulic Filter Restriction Indicators Two Way Electric Solenoid

Moderate Modifications

Expanded Hydraulic Plumbing Kit Installs Guards for Windows/Cab Top/Booms
Jump Start Kits Rear Window Defrost Kits
Level 1 Corrosion Package Blade/Ripper/Winch
Complex AT Field Kits Hydraulic Attachments (Couplers/Thumbs)

Complex Conversions

Full Machine Guarding Installs Cab Riser/Positioners
AFEX Fire Suppression Systems Long Reach Booms
Lincoln Lube Systems Positive Air Shutoff
Snow Wing Installs multi-functional Attachment Installs

Why Choose CustomWorks?

Flexibility. The experienced technicians at CustomWorks will work to customize a solution specifically for you. We can provide the parts, or coordinate the whole process and ship a finished product, ready to use, and hassle-free. Bring us your challenges and let us help you.



CWS is known for designing, engineering and manufacturing top-quality cabs, conversions and attachments for heavy machinery. Due to high quality performance, reliability and service, CWS products are in demand and utilized worldwide in many industries including some of the harshest climates across the globe.

Engineering and manufacturing capabilities allow CWS to produce attachments for the smallest to largest heavy machinery in the world including backhoes, wheel loaders, dozers, articulated trucks and tractors, motor graders and more. All products are covered with the most comprehensive warranty package in the industry.

Serving Your Market

- Mining
- Oil & Gas
- Construction
- Agriculture
- Forestry
- Material Handling

Attachment Solutions

- Wheel Loader Buckets
- Snow Removal
- Grapples
- Excavator Buckets
- Rakes
- Blades
- Rippers
- Lifting Devices
- Hydraulic Thumbs
- Forestry Products

WHEEL LOADERS / BACKHOE LOADERS

BUCKETS

| | |
|----------------------------------|----|
| General Purpose Buckets | 10 |
| Multi-Purpose Buckets..... | 10 |
| Light Material Buckets | 11 |
| Refuse / Transfer Buckets..... | 11 |
| Grapple Buckets..... | 12 |
| Grapple Buckets / Rakes | 13 |
| Side Dump Buckets..... | 13 |
| Woodchip Buckets..... | 14 |
| Straight Edge Rock Buckets | 14 |
| Spade Nose Rock Buckets | 14 |

COUPLERS & ATTACHMENTS

| | |
|--|----|
| Single Interchange Couplers..... | 15 |
| NEXUS™ Cast Multi Pick-Up Coupler..... | 15 |

FORKS

| | |
|---------------------------------|----|
| Construction Utility Forks..... | 16 |
| Clamp Forks, Paddle Top..... | 16 |
| Pipe Forks..... | 17 |

SPECIALTY ATTACHMENTS

| | |
|------------------------|----|
| Extendable Booms | 18 |
| Angle Brooms..... | 18 |
| Loader Rakes..... | 19 |
| Mat Grapple | 20 |

MINI / EXCAVATORS / BACKHOES

BUCKETS

| | |
|---|----|
| Heavy & Severe Duty Buckets..... | 24 |
| Quick Hitch™ Heavy-Duty Buckets | 25 |
| Mini Ex Pin On Bucket | 25 |
| Clean Up Bucket | 26 |
| Continuous Edge Bucket..... | 26 |
| Ditch Cleaning Buckets..... | 27 |
| Quick Hitch™ Ditch Cleaning Buckets | 27 |
| Swinger Buckets..... | 28 |

Bell Hole Buckets..... 28
 Coral Rock Buckets 29

COUPLERS

Quick Hitch™ Coupler..... 30
 DuraLatch™ Coupler..... 30
 PowerLatch® Tilt Coupler 31
 SmartLoc® Coupler..... 31

THUMBS

Main Pin Hydraulic Thumb 32
 Progressive Link Hydraulic Thumb 32
 Weld-On Hydraulic Thumb..... 33

SPECIALTY ATTACHMENTS

Heavy Duty Rippers..... 34
 Clearing Rake..... 34
 STANLEY® MB/XP Series Breakers..... 35
 StrikeForce® Breakers 36
 StrikeForce® TPC Vibratory Plate Compactors 37
 StrikeForce® TWC Wheel Compactors 37

CUSTOM WORKS

Case Loader Waste Package Guard..... 40
 Case Dozer Landfill Package 42
 Case Dozer Forestry Package..... 44
 Case SSL Forestry Package 45
 Excavator Cab Guarding..... 46

SPECIALTY PRODUCTS

Forestry Grapple 50
 Tree Length Grapple..... 50
 Excavator Mat Grapple..... 51
 Logging Grapple 51
 Cable Reelers..... 52
 Dozer Blades..... 52
 Tire Manipulators..... 53



WHEEL LOADERS // BACKHOE LOADERS



GENERAL PURPOSE BUCKETS



FEATURES

- Material density 1800 to 3000 pounds
- Sloped-bottom design allows for maximum fill capabilities and material retention
- Slope bottom increases dump angle by 5° for more efficient dumping capabilities
- Minimum 36 KSI yield steel construction
- Minimum 400 Brinell wear areas
- Custom buckets available by request
- Rubber edges available by request
- Widths and cutting edge hole patterns drilled to OEM standard wear parts specification
- Available as pin-on or compatible with Quick Coupler System



MULTI-PURPOSE BUCKETS



FEATURES

- Versatile in handling excavating, grappling, loading, and top dumping
- Double bottom clam floor design provides greater strength and durability
- Equipped with standard bolt-on moldboard cutting edges; heat-treated steel pins and bushings; heavy-duty hydraulic cylinders with protected hydraulic lines; greased pivot pins
- Clam-front cutting edge drilled to OEM standard wear parts specification
- Available as pin-on or compatible with JRB's Quick Coupler System
- Third function loader hydraulics and jumper hose kit for Quick Coupler required for operation. Bucket supplied with attachment side whip hoses



LIGHT MATERIAL BUCKETS



FEATURES

- Designed for capacity of 1800 pounds per cubic yard
- Sloped-bottom design allows for maximum fill capabilities and material retention
- Slope Bottom increases dump angle by 5° for more efficient dumping capabilities
- Minimum 36 KSI yield steel construction
- Minimum 400 Brinell wear areas
- Optional visibility spill guard available
- Widths and cutting edge hole patterns drilled to OEM standard wear parts specification
- Available as pin-on or compatible with JRB's Quick Coupler System



REFUSE / TRANSFER BUCKETS



FEATURES

- Specifically designed for use in landfill and transfer station applications
- Bucket width and edge hole pattern drilled to accept specific OEM standard wear parts
- Available in either Pushing or Loading profile designs
- Heavy-Duty round tube design visibility spill guard
- All base bucket material made from minimum 36 KSI yield steel
- All wear areas made from minimum Brinell hardness of 400
- Refuse Buckets available as pin-on or for use with Quick Coupler system
- For material weighing up to 1000 pounds per cubic yard
- Rubber edges available by request



GRAPPLE BUCKETS



FEATURES

- Profiles available in full, half-cutaway, or full-cutaway sides for any job application
- Optional screening on arms available for maximum material retention
- Dual hydraulic cylinders allow independent actuation of each cylinder for clamping uneven loads
- Width and edge hole patterns drilled to OEM standard wear parts
- Available as pin-on or compatible with Quick Coupler System
- Third function loader hydraulics and jumper hose kit for Quick Coupler required for operation. Bucket supplied with attachment side whip hoses
- Rubber edges available by request

100
CLASS200
CLASS300
CLASS500
CLASS600
CLASS700
CLASS800
CLASS900
CLASS

GRAPPLE BUCKETS / RAKES



FEATURES

- Efficient design for loading tires, land clearing, and trash handling
- Multi-tine grapples allow for better material retention
- Dual hydraulic cylinders allow independent actuation of each cylinder for clamping uneven loads
- Optional sidebars available
- Available as pin-on or compatible with Quick Coupler System
- Third function loader hydraulics and jumper hose kit for Quick Coupler required for operation. Bucket supplied with attachment side whip hoses

100
CLASS200
CLASS300
CLASS500
CLASS600
CLASS700
CLASS800
CLASS900
CLASS

SIDE DUMP BUCKETS



FEATURES

- Designed for confined, hard-to-maneuver areas
- Supports capacity of .75 to 4.5 cubic yards
- Features left-hand dump function, right-hand available by request
- Heavy-duty design allows for full side dumping and angle backfilling
- Side-shoot dumping angle of 45°
- Features the exclusive JRB sequence valve for lock/unlock of the bucket cradle and side dump function
- Center mounted lift hooks are standard
- Available as pin-on or compatible with Quick Coupler System
- Third function loader hydraulics and jumper hose kit for Quick Coupler required for operation. Bucket supplied with attachment side whip hoses



WOODCHIP BUCKETS



FEATURES

- Larger capacity for handling lightweight materials
- Designed specifically for large loads of wood
- Top screen maintains bucket capacity and increases visibility
- Maximum performance and service for woodchip handling applicators



STRAIGHT EDGE ROCK BUCKETS



FEATURES

- Capable of penetrating most rock applications
- 400 Brinell high strength, alloy steel construction
- Features heavy-duty, heat-treated cutting edges; replaceable weld-on wear pads; and heavy-duty, steel-tube-reinforced spill guards
- Standard Options - Bolt on Teeth, Bolt on Edge (Weld-on available by request)
- Width and edge pattern are drilled to OEM standard wear parts specification
- Available as pin-on or compatible with Quick Coupler System

100
CLASS200
CLASS300
CLASS500
CLASS600
CLASS700
CLASS800
CLASS900
CLASS

SPADE NOSE ROCK BUCKETS



FEATURES

- Designed for handling loose rock or digging in severe applications
- Available with standard "V" or modified "V" style edge
- 400-500 Brinell high strength, alloy steel construction
- Standard equipped with heavy-duty, heat-treated cutting edges; replaceable weld-on wear pads; and heavy-duty, steel-tube-reinforced spill guards
- Weld-on teeth standard, bolt-on teeth available by request

100
CLASS200
CLASS300
CLASS500
CLASS600
CLASS700
CLASS800
CLASS900
CLASS

SINGLE INTERCHANGE COUPLERS

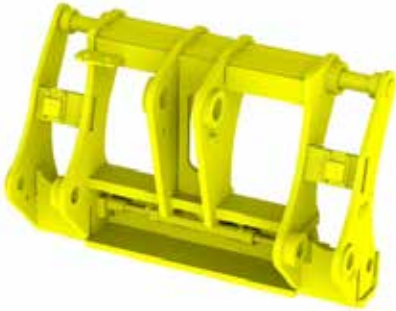

FEATURES

JRB has been the leader in wheel loader couplers since the introduction of its JRB interchange couplers over 30 years ago. Our couplers are designed to provide exceptional visibility while providing strength and durability needed to handle any task. JRB single interchange couplers provide added versatility to your loader. Quickly change attachments without leaving the cab.

- Available in JRB and ISO interchanges
- Maximum visibility in key areas for easier operation of forks or when connecting attachments

NEXUS™ CAST MULTI PICK-UP COUPLER



A Frame



B Frame

FEATURES

- Patented, replaceable ISO pins and 416 collars extend the life of the coupler
- Cast design adds strength and durability
- Coupler is constructed out of cast steel which does not interfere with the ability to weld or grind on the coupler if necessary
- Hydraulic plunger visibility aids in proper attachment engagement
- Optimized coupler weight distribution improves center of gravity ratio for improved load stabilization
- 167 square inches of visibility added to the center of the coupler for improved load management and safer operation
- Certain OEM attachments may not fit properly with interchange couplers
- Includes JRB Hydraulic installation kit
- Available for select machines in 200, 300 & 500 classes



CONSTRUCTION UTILITY FORKS



FEATURES

- Available as pin-on or for use with Quick Coupler System
- Available with manually adjustable tines or hydraulically actuated tines for side-to-side adjustments from the cab
- Tine static load capacities are rated beyond loader lift capabilities
- Fork carriage widths range from 60" to 106"
- Tine lengths range from 48" to 96"
- Larger 3" round bar for Class 200-500
- New design for Class 200-500 offers improved center of gravity for better load management
- Third function loader hydraulics and jumper hose kit for Quick Coupler required for hydraulic fork operation. Hydraulic forks supplied with attachment side whip hoses
- NOTE: Special order carriage width and tine length available upon request. Tipping load charts available upon request

100
CLASS

200
CLASS

300
CLASS

500
CLASS

600
CLASS

700
CLASS

800
CLASS

900
CLASS

CLAMP FORKS, PADDLE TOP



FEATURES

- Designed for maximum material retention and strength in loading and unloading logs, lumber, and palletized materials
- Ideal for picking and sorting applications
- High-strength steel tines
- Adjustable tines standard and available with optional floating-tine design for uneven terrain conditions
- Heat-treated pins and bushings
- Custom tine lengths and carriage widths available by request
- Available as pin-on or compatible with Quick Coupler System
- Third function loader hydraulics and jumper hose kit for Quick Coupler required for fork operation. Forks supplied with attachment side whip hoses

100
CLASS

200
CLASS

300
CLASS

500
CLASS

600
CLASS

700
CLASS

800
CLASS

900
CLASS

PIPE FORKS



FEATURES

- Specifically designed for pipe handling
- Drop-forged, fixed tines
- Rugged carriage construction
- Custom carriage widths and tine lengths available
- Available as pin-on or compatible with JRB's Quick Coupler System
- Available for 200, 300, 500, 600 and 700 classes

100
CLASS

**200
CLASS**

300
CLASS

500
CLASS

600
CLASS

**700
CLASS**

800
CLASS

900
CLASS

EXTENDABLE BOOMS



FEATURES

- Designed for long-reaching material handling applications involving lifting, loading, and positioning
- Superior efficiency in handling large-diameter precast pipes
- High-strength tubular steel construction
- Manually extendable
- Standard equipped with hook
- Available as pin-on or compatible with Quick Coupler System
- Capacity is based upon the hydraulic limitation or tip limitation of your machine
- Please refer to your loaders specific ratings
- Stinger boom available for 100 class
- NOTE: Tipping load charts available by request

100
CLASS200
CLASS300
CLASS500
CLASS600
CLASS700
CLASS800
CLASS900
CLASS

ANGLE BROOMS



FEATURES

- Dual-motor design for high torque
- Quick-change brush without breaking hydraulic lines
- Third valve required to operate; fourth valve required to operate optional hydraulic angle change
- Parallel linkage allows sweeper to follow ground contours
- Manual angle 30 degrees left/right is standard
- Choose poly, wire, or poly/wire brush

100
CLASS200
CLASS300
CLASS500
CLASS600
CLASS700
CLASS800
CLASS900
CLASS

LOADER RAKES

LOADER RAKE



FEATURES

- Designed for removing and piling brush in heavy land-clearing situations
- Available in various raking widths and capacities to match loader specifications
- Optional hydraulic end clamps available to provide secure load control and increased load capacities
- Rakes available as pin-on or compatible with Quick Coupler System
- Third function loader hydraulics and jumper hose kit for Quick Coupler required for hydraulic clamp operation. Hydraulic rakes supplied with attachment side whip hoses

LOADER RAKE WITH CLAMP



100
CLASS

200
CLASS

300
CLASS

500
CLASS

600
CLASS

700
CLASS

800
CLASS

900
CLASS

MAT GRAPPLE



FEATURES

- Safely and efficiently handling rig mats
- Rugged design for harsh environments
- Concealed and protected hydraulic
- Accessible service plate cover
- Open design for optimized visibility
- 200, 300, and 500 classes

100
CLASS

200
CLASS

300
CLASS

500
CLASS

600
CLASS

700
CLASS

800
CLASS

900
CLASS



MINI // BACKHOES // EXCAVATORS



HEAVY & SEVERE DUTY BUCKETS

HEAVY-DUTY



FEATURES

- Optimized profile for better filling & dumping
- Dual taper design provides enhanced heel clearance for less resistance and wear during digging
- Improved construction reduces weight up to 10% for larger payloads
- One-piece header design improves load distribution and durability
- Strategic placement of AR400 wear material in the cutting edge, side cutter and bottom corner to reduce wear

SEVERE-DUTY



02 mT

03 mT

05 mT

BH 13'-17'

08 mT

BH 17'+

12 mT

15 mT

20 mT

25 mT

27 mT

35 mT

45 mT

60 mT

80 mT

QUICK HITCH™ HEAVY-DUTY BUCKETS



FEATURES

- Unique, long floor design for superior trenching and grading
- Curved side edges reduce stress and enhance power concentration in dig cycle
- Manufactured using high-quality materials with protected welds for superior wear resistance and durability
- AR400 shell, cutting edge and side edges provide superior wear-resistance over traditional mild steel design without compromising structural integrity
- Double-radius curl geometry allows for:
 - Aggressive Digging
 - Optimal Bucket Capacities
 - Minimal Heel Drag

| | | | | | | | | |
|-------|-------|-------|------------|-------|---------|-------|-------|-------|
| 02 mT | 03 mT | 05 mT | BH 13'-17' | 08 mT | BH 17'+ | 12 mT | 15 mT | 20 mT |
| 25 mT | 27 mT | 35 mT | 45 mT | 60 mT | 80 mT | | | |

MINI EX PIN ON BUCKETS



FEATURES

- AR400 wear resistant plate used to reduce weight and improve wear life
- Dual taper design provides enhanced heel clearance for less resistance and wear during digging
- Long floor design for easier trenching and better filling of the bucket

| | | | | | | | | |
|-------|-------|-------|------------|-------|---------|-------|-------|-------|
| 02 mT | 03 mT | 05 mT | BH 13'-17' | 08 mT | BH 17'+ | 12 mT | 15 mT | 20 mT |
| 25 mT | 27 mT | 35 mT | 45 mT | 60 mT | 80 mT | | | |

CLEAN UP BUCKETS



FEATURES

- Improved construction reduces weight up to 10% for larger payloads
- Extra wide widths available for maximum payloads
- Optimized profile for better filling & dumping
- Dual taper design provides enhanced heel clearance for less resistance and wear during digging
- One-piece header design improves load distribution and durability
- Strategic placement of AR400 wear material in cutting edge, side cutter and bottom corner to reduce wear

| | | | | | | | | |
|-------|-------|-------|------------|-------|---------|-------|-------|-------|
| 02 mT | 03 mT | 05 mT | BH 13'-17' | 08 mT | BH 17'+ | 12 mT | 15 mT | 20 mT |
| 25 mT | 27 mT | 35 mT | 45 mT | 60 mT | 80 mT | | | |

CONTINUOUS EDGE BUCKETS



FEATURES

- Improved construction reduces weight up to 10% for larger payloads
- Extra wide widths available for maximum payloads
- Optimized profile for better filling & dumping
- Dual taper design provides enhanced heel clearance for less resistance and wear during digging
- Teeth are spaced as tightly as possible to present a continuous edge
- Corner teeth are straight/in-line with the center teeth
- Equipped with Flare/Spade teeth

| | | | | | | | | |
|-------|-------|-------|------------|-------|---------|-------|-------|-------|
| 02 mT | 03 mT | 05 mT | BH 13'-17' | 08 mT | BH 17'+ | 12 mT | 15 mT | 20 mT |
| 25 mT | 27 mT | 35 mT | 45 mT | 60 mT | 80 mT | | | |

DITCH CLEANING BUCKETS

PIN-ON



FEATURES

- Bolt-on edge available for extended bucket usage
- Double Bottom for longer bucket life
- Gusseted as required
- Ideal for storm ditch cleaning
- Optional drain holes available

QUICK HITCH™

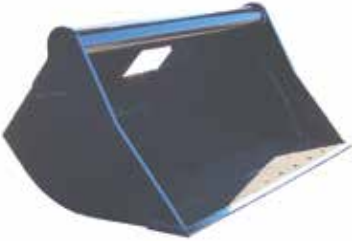

FEATURES

- Bolt-on edge available for extended bucket usage
- Center gusset available for most models
- Ideal for storm ditch cleaning

| | | | | | | | | |
|-------|-------|-------|------------|-------|---------|-------|-------|-------|
| 02 mT | 03 mT | 05 mT | BH 13'-17' | 08 mT | BH 17'+ | 12 mT | 15 mT | 20 mT |
| 25 mT | 27 mT | 35 mT | 45 mT | 60 mT | 80 mT | | | |

SWINGER BUCKETS



FEATURES

- An ideal addition for your excavator. Ditching, slope work, grading, backfilling, land clearing, and waste handling applications
- Cylinders protected from outside debris and damage
- Tilts in 45° angle in two directions
- Available in widths from 48" to 96"
- Capacity ranges from .50 to 3.00 cubic yards
- Manufactured for excavators weighing from 25000 lbs. through 100,000 lbs

02 mT

03 mT

05 mT

BH 13'-17'

08 mT

BH 17'+

12 mT

15 mT

20 mT

25 mT

27 mT

35 mT

45 mT

60 mT

80 mT

BELL HOLE BUCKETS



FEATURES

- Digs straight walls for cemetery requirements
- Custom sizes available
- T-1 cutting edge
- Available as pin-on (limited coupler options)

02 mT

03 mT

05 mT

BH 13'-17'

08 mT

BH 17'+

12 mT

15 mT

20 mT

25 mT

27 mT

35 mT

45 mT

60 mT

80 mT

CORAL ROCK BUCKETS



FEATURES

- Performs Severe Duty applications
- Weld-on wings for peeling away coral rock
- Operates under frost conditions
- Side wear pads for extra durability
- Buckets are equipped with standard Hensley X156 Teeth

BUCKETS

| | | | | | | | | |
|-------|--------------|--------------|-------------------|-------|---------|-------|-------|-------|
| 02 mT | 03 mT | 05 mT | BH 13'-17' | 08 mT | BH 17'+ | 12 mT | 15 mT | 20 mT |
| 25 mT | 27 mT | 35 mT | 45 mT | 60 mT | 80 mT | | | |

QUICK HITCH™ COUPLER



FEATURES

- Simple hook design increases contact face providing superior wear-resistance
- Optimal weld locations maximize structural integrity and product longevity
- Hook style will fit all first generation Quick Hitch™ buckets
- Hooks manufactured with high strength steel plates

| | | | | | | | | |
|-------|-------|-------|------------|-------|---------|-------|-------|-------|
| 02 mT | 03 mT | 05 mT | BH 13'-17' | 08 mT | BH 17'+ | 12 mT | 15 mT | 20 mT |
| 25 mT | 27 mT | 35 mT | 45 mT | 60 mT | 80 mT | | | |

DURALATCH™ COUPLER



- Fully cast body from high strength steel, delivering exceptionally strong performance
- Simple, compact design improves reliability: Fewer moving parts than typical couplers means less to go wrong
- Twin locking back up system including an internal ISO gas spring cylinder which ensures the attachment remains securely engaged in a working position in the event of hydraulic loss
- Up to 42% lighter than certain competitors
- The low-profile design delivers a shorter pin to point measurement which allows maximum breakout force for greater productivity and efficiency

| | | | | | | | | |
|-------|-------|-------|------------|-------|---------|-------|-------|-------|
| 02 mT | 03 mT | 05 mT | BH 13'-17' | 08 mT | BH 17'+ | 12 mT | 15 mT | 20 mT |
| 25 mT | 27 mT | 35 mT | 45 mT | 60 mT | 80 mT | | | |

POWERLATCH® TILT COUPLER



- The PowerLatch Tilt Coupler combines the versatility of the PowerLatch multi-pin grabber coupler with the ability to tilt the attachment a full 90° in each direction allowing you to reach more places in less time and with less repositioning
- 180° tilt allows you to achieve more from your excavator without repositioning
- Dual ABS independent back up system for quick, safe attachment changes
- Pick up attachments within the same class regardless of the OEM make
- No maintenance, sealed actuator keeps coupler working longer

| | | | | | | | | |
|-------|-------|-------|------------|--------------|---------|--------------|--------------|--------------|
| 02 mT | 03 mT | 05 mT | BH 13'-17' | 08 mT | BH 17'+ | 12 mT | 15 mT | 20 mT |
| 25 mT | 27 mT | 35 mT | 45 mT | 60 mT | 80 mT | | | |

SMARTLOC® COUPLER

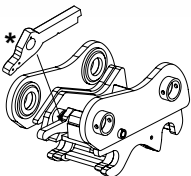

**Automatically sequenced
Secondary Lock.**

- Reliable, time-tested coupler with unique wedge design features effortless tool changes from cab
- Locking cylinder with check valve prevents unlocking
- Locking mechanism maintains continuous pressure against the pin
- 1/2" to 3/4" pin spacing tolerance for attachment versatility
- Easy-to-install hydraulic kit with bucket cylinder hydraulics
- Excavating stick with mounted hydraulic components
- In-cab, safety controls with unlocked indicator light, audible unlock buzzer, and locking toggle switch
- Wedge Locking System adjusts for wear keeping a tight connection
- Maintains short vertical offset, keeping the alignment closer to the machine
- All couplers include JRB machine specific hydraulic installation kit and one set of attachment pins. Kit utilizes bucket curl cylinder hydraulic source. Designate exact machine model and stick length to ensure proper installation kit

| | | | | | | | | |
|--------------|--------------|--------------|--------------|--------------|---------|--------------|--------------|--------------|
| 02 mT | 03 mT | 05 mT | BH 13'-17' | 08 mT | BH 17'+ | 12 mT | 15 mT | 20 mT |
| 25 mT | 27 mT | 35 mT | 45 mT | 60 mT | 80 mT | | | |

MAIN PIN HYDRAULIC THUMB



FEATURES

- Minimal welding for quick install and less stress on critical boom structures
- Field replaceable components make it easy to replace common wear items onsite with minimal downtime

02 mT

03 mT

05 mT

BH 13'-17'

08 mT

BH 17'+

12 mT

15 mT

20 mT

25 mT

27 mT

35 mT

45 mT

60 mT

80 mT

PROGRESSIVE LINK HYDRAULIC THUMB



FEATURES

- Lightweight design provides peak machine stability and allows for more payload and lower fuel consumption
- Progressive linkage allows for added rotation over that of a Main Pin Hydraulic Thumb

02 mT

03 mT

05 mT

BH 13'-17'

08 mT

BH 17'+

12 mT

15 mT

20 mT

25 mT

27 mT

35 mT

45 mT

60 mT

80 mT

WELD-ON HYDRAULIC THUMB



FEATURES

- Hydraulic action for versatile thumb positioning
- Low profile thumb storage for better visibility
- Grease zerks positioned for protection from the elements
- Lock-back bracket for hydraulic cylinder safety
- Multiple T-1 steel tines for rugged construction and longer wear life
- Non bucket dependent fit up
- Stiff-Arm Mechanical versions also available

| | | | | | | | | |
|-------|-------|-------|-----------|-------|---------|-------|-------|-------|
| 02 mT | 03 mT | 05 mT | BH 13-17' | 08 mT | BH 17'+ | 12 mT | 15 mT | 20 mT |
| 25 mT | 27 mT | 35 mT | 45 mT | 60 mT | 80 mT | | | |

HEAVY DUTY RIPPERS



FEATURES

- Ripper design reduces stress exerted on machine
- Powerful ripping ability for kaliche, frost, or rock
- Compatible with most pin-grabbing couplers
- Available as pin-on or Quick Hitch attachment

02 mT

03 mT

05 mT

BH 13'-17'

08 mT

BH 17'+

12 mT

15 mT

20 mT

25 mT

27 mT

35 mT

45 mT

60 mT

80 mT

CLEARING RAKE



FEATURES

- Useful for land clearing
- Can be built to mesh with hydraulic thumbs
- Available in various widths and configurations

02 mT

03 mT

05 mT

BH 13'-17'

08 mT

BH 17'+

12 mT

15 mT

20 mT

25 mT

27 mT

35 mT

45 mT

60 mT

80 mT

STANLEY® MB/XP SERIES BREAKERS

LARGE SIZE



FEATURES

- Membrane Type Accumulator eliminates time consuming recharging
- Fixed Impact Energy Valve allows for use on a wider range of carriers
- Heavy Duty Housings and Wear Plates for extreme durability in the harshest of applications
- Vibration Dampening Tie-Rods maximizes uptime
- Stroke Selector to increase blow rate and decrease energy for various applications as a way to maximize efficiency (applicable for all large-sized breakers only)
- Idle Blow Protector prevents blank firing
- Sound Suppressed Housing dampen operating volume
- Hydraulic Overflow Protector for added durability
- Adapters for Remote Lubricators, and Air Line for underwater work

MID-SIZE



FEATURES

- MBX series breakers feature a patented valve system that dramatically increases the durability and performance of the tool. Less maintenance is required over the life of the breaker because the design has only two moving parts, limiting the need for servicing
- Packs serious force and is designed to break a wide array of materials. It's destined to be the tool of choice for demolition, trenching, tunneling, and boulder breaking. Packed with power and ready to ship – the MB/X series offers years of worry-free breaking performance

| | | | | | | | | |
|-------|-------|-------|------------|-------|---------|-------|-------|-------|
| 02 mT | 03 mT | 05 mT | BH 13'-17" | 08 mT | BH 17'+ | 12 mT | 15 mT | 20 mT |
| 25 mT | 27 mT | 35 mT | 45 mT | 60 mT | 80 mT | | | |

STRIKEFORCE® BREAKERS



FEATURES

- 2 Tool Bits
- 1 Extra Seal Kit
- Durable and reliable construction with only two moving parts
- Proven working principle
- Breakers give the contractor a range of demolition and construction tools to address tasks commonly found on the job site. These tools combine power and blow rate to deliver optimum breaking performance in tasks such as utility trenching or site preparation

02 mT

03 mT

05 mT

BH 13'-17'

08 mT

BH 17'+

12 mT

15 mT

20 mT

25 mT

27 mT

35 mT

45 mT

60 mT

80 mT

STRIKEFORCE® TPC VIBRATORY PLATE COMPACTORS



FEATURES

- "Outboard" isolator location provides stability for optimal transmission of impulse for effective compaction
- Shock isolators are angled to reduce damaging shear stresses in the isolator and extend life while providing a performance advantage in delivering compaction forces to soil
- Integral Flow Control block manages flow and pressure to provide effective and repeatable compaction as well as to protect the hydraulic motor
- Oil bath bearing design maximizes bearing life while minimizing maintenance needs
- Paladin Boom Mounted TPC Plate Compactors provide the perfect combination of impulse force and frequency for handling trench and surface compaction needs of the contractor in road construction and repair, embankment preparation, utility and waste drain excavation backfill, as well as special needs in sheet, post and plate driving for soil stabilization

| | | | | | | | | |
|-------|-------|-------|------------|-------|---------|-------|-------|-------|
| 02 mT | 03 mT | 05 mT | BH 13'-17' | 08 mT | BH 17'+ | 12 mT | 15 mT | 20 mT |
| 25 mT | 27 mT | 35 mT | 45 mT | 60 mT | 80 mT | | | |

STRIKEFORCE® TWC WHEEL COMPACTORS



FEATURES

- Extended Compaction Pad life through use of abrasion resistant Hardox 450 material
- Enhanced durability through the use of an oversized axle shaft and large diameter bearings to minimize contact loads and lubrication requirement
- Fully protected grease locations for use in abusive environments. These are not susceptible to damage in typical work environment as with competitor designs
- Minimized maintenance through the use of a large diameter greased zinc alloy bearing which also protects the axle shaft and housings from damage

| | | | | | | | | |
|-------|-------|-------|------------|-------|---------|-------|-------|-------|
| 02 mT | 03 mT | 05 mT | BH 13'-17' | 08 mT | BH 17'+ | 12 mT | 15 mT | 20 mT |
| 25 mT | 27 mT | 35 mT | 45 mT | 60 mT | 80 mT | | | |



CUSTOMWORKS®



CASE LOADER WASTE PACKAGE GUARD

The Case Loader Waste Package provides machine and operator protection in harsh landfill, waste station and forestry environment.



HD FRONT FRAME COVER

Features: Replaces original cover to eliminate openings that debris could enter.



FRONT FRAME/AXLE COVER

Features: Seals the opening between the front frame and axle and prevents debris from entering the front frame.



LIFT CYLINDER GUARDS

Features: The guards protect the cylinder hoses and fittings while the flexible covers prevent debris build-up inside the frame. Bolt-on design.



FRONT LIGHT GUARDS

Features: Protect lights from damaging debris. Bolt-on design.



FRONT WINDOW GUARD

Features: Protects the cabs front glass from damage with minimal obstruction to the operator's view.



ARTICULATION GUARD

Features: Covers reduce openings in hinge area to prevent entry of debris. Easily removable for access to the inner frames.



FRONT FRAME CYLINDER HOSE COVER

Features: Covers prevent debris from collecting in cylinder mounting areas and protects cylinder hoses from damage. Bolt-on design.



FRONT BELLY GUARD

Features: Protects front drive components and prevents debris entry into front frame. Includes access panel for routine maintenance/inspection.



REAR BELLY GUARD

Features: Provides additional fuel tank protection and prevents debris from entering the rear frame behind the axle.



AXLE SEAL GUARDS

Features: Prevents build-up of debris between the axle and rim as well as any wires and other material that may wrap around the axle.



RAISED ENGINE AIR PRE-CLEANER

Features: Clamps to the existing air intake and ensures longer air filter life. Has an improved fuel economy and better performance.



REAR LIGHT GUARDS

Features: The guards protect the rear lights from damage caused by debris. Can easily be removed for light maintenance.



FLEXIBLE LADDER STEP

Features: Replaces the more rigid OEM lower step. The flexible rubber deflects debris and the curved design prevents any snagging.



REAR WINDOW GUARD

Features: Protects the rear cab glass from damage. The guard hinges upward to provide access to cooling package cover. Bolt-on design.



TRANSMISSION GUARD

Features: Protects transmission and hydraulic components and prevents any debris from entering the rear frame. Bolt-on design.

CASE DOZER LANDFILL PACKAGE

The Case Dozer Landfill Package provides machine protection in harsh landfill waste environment.



HD RADIATOR DOOR

HEAVY DUTY LOUVER GRILLE GUARD PROTECTS RADIATOR FROM DEBRIS



SEMI-U TRASH RACK

SEMI-U BLADE TRASH RACK INCREASES BLADE CAPACITY TO 14.5 CUYD AND OVER ALL HEIGHT TO 79"



WEIGHT PACK

WEIGHT PACK FOR FIREBOX ADDS 1540 LBS



FIREBOX

COUNTERWEIGHT FIREBOX WITH REAR STRIKERS, TOW STRAP KEEPERS, AND TOW PIN 2860 LBS



TANK GUARD

TANK GUARD WITH DEBRIS DEFLECTORS REDIRECTS MATERIAL AWAY FROM CHASSIS AND PROTECTS REAR TANK FROM IMPACT



LIFT CYLINDER HOSE GUARDS

COVER HOUSES AND PROTECTS HANGING LIFT CYLINDER HOSES FROM ENTANGLEMENT



GREASE FITTING PROTECTION

WELDED RINGS GUARD ALL GREASE FITTINGS



SEMI-U BLADE HOSE GUARD

PROTECTS THE EXPOSED HYDRAULIC HOSES MOUNTED ALONG THE BLADE



LIFT / TILT CYLINDER GUARDS

PROTECTS FLOW PIPING UNDERNEATH LIFT CYLINDERS FROM DAMAGE
HEAVY DUTY TILT CYLINDER COVER



STEP EXTENSION

EXTENDS STEP COVERAGE AND INCREASES DOOR PROTECTION

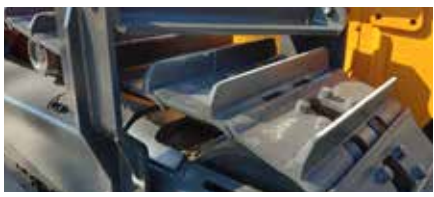

FRONT STRIKER BARS

PREVENTS MATERIAL FROM CLIMBING TRACKS AND DEFLECTS IT AWAY FROM CHASSIS
DEFLECTS MATERIAL AWAY FROM DOZER FRAME



DEFLECTOR BARS

DEFLECTS MATERIAL AWAY FROM DOZER FRAME



REAR WINDOW SCREEN

REAR WINDOW SCREEN 2"X2" PATTERN



ENGINE PRECLEANER KIT

SY-KLONE SERIES 9000 PRECLEANER WITH SCREEN PREVENTS DEBRIS FROM ENTERING THE ENGINE AIR INTAKE SYSTEM



A/C MODULE GUARD

SCREEN COVER PROTECTS OEM A/C MODULE AND CAB REAR LIGHTS



FINAL DRIVE SEAL GUARDS

GUARD PREVENTS MATERIAL ENTERING AND DAMAGING DRIVE SEAL

CASE DOZER FORESTRY PACKAGE

The Case Dozer Forestry Package provides machine and operator protection in harsh forestry and land clearing environment.



FRONT WINDOW SCREEN

Features: Protects the front window from debris and has a tool-less removal for easy window cleaning. Bolt-on design. ISO 8084 certified.



DOOR WINDOW SCREENS

Features: Protects the cab door windows from debris and has a tool-less opening from the inside and out for emergency egress. Hinged for window cleaning. Bolt-on design. ISO 8084 certified.



SIDE WINDOW SCREENS

Features: Protects the cab side windows from debris. No welding is required for installation. Includes a tool-less opening from the inside out for an emergency egress and hinges out for window cleaning. Bolt-on design. ISO 8084 certified.



A/C MODULE GUARD

Features: Protects the air conditioner module on the rear of the cab and has removable light guards. Compatible with CNH rear screen. Some welding is required for installation. A rear discharge version is available.



REAR WINDOW SCREEN

Features: This heavy-duty design protects the cab in harsh environments. Easily installs to cab with no welding or drilling. Prop rod included to hold guard out of the way for easy cleaning and maintenance.



FRONT LIGHT GUARD

Features: Bolt-on design requires no drilling to install. Guards 4 OEM headlights (2 mount on guard, 2 on front window guard). Compatible with sweep equipped machines.

CASE SSL FORESTRY PACKAGE



HYDRAULIC CONNECTION GUARDS

Features: Heavy-duty formed 3/16" steel plate. Easy bolt-on installation and welding is not needed. Complete Connect Under Pressure (CUP) manifold protection. Hinged guards for CUP manifold access.



REAR BUMPER

Features: Heavy-duty formed steel plate construction. Bolt-on design requires no welding and does not interfere with OEM tie-down hook access or compartment doors. Departure angle of 21°



SWEEP

Features: Protects rear of machine from falling debris. Tool-less opening from the inside and out and hinges up for emergency egress.



REAR GRILL GUARD

Features: Attaches to heavy duty rear bumper. The heavy-duty upper mounts weld to the frame and protects radiator from debris while allowing ample airflow. Swings open to allow unhindered access to engine compartment.



TOP GUARD WITH LIGHT GUARDS

Features: Supported by cab frame and held in place using existing rivnuts. Maintains top window visibility with a low profile design to avoid tree limbs.



INTAKE SCREENS

Features: Filters debris from entering air cooler area. Helps prevent overheating issues and prolongs life of coolers. Bolt-on design (hole modification required), but welding is not required. Replaceable steel mesh screen design.



SIDE SCREENS

Features: Built with a heavy-duty design to protect cab glass. Can also be used to replace OEM side screens when being used in harsh environments.

EXCAVATOR CAB GUARDING



Wire Mesh Window Guard Pictured.

FRONT WINDOW GUARD, WIRE & POLYCARBONATE

Available in Scratch Resistant Polycarbonate (½" or ¼" Thick) or Wire Mesh.

Protects window from flying debris and utilizes existing mounting locations for easy bolt-on installation. Has a replaceable and interchangeable front screen. It is hinged at the top for easy access to front glass and is contoured to fit front of cab. Sturdy, Fabricated, Steel Frame and Mounting Brackets.

Available for Komatsu, Deere, CAT, Doosan, and Kobelco Excavators.



FOLDING VANDAL GUARDS

Prevents windows from being broken by vandals. It has a lightweight aluminum construction and no tools required to install guards once hanger brackets are installed. Includes keyed-alike padlocks to secure guards to cab. Covers all windows except roof hatch.

Available for Komatsu Excavators.



TOP GUARD

Protects top of cab from falling debris. Includes mounting locations for vandal guard and front working lights. Heavy-duty construction complements Paladin front window guard. Bolt-on design. Welding is not required.

Available for Komatsu, Deere, and Kobelco Excavators.

**OPEN ROPS POLYCARBONATE FRONT GUARD**

Easily bolts to ROPS frame with no welding required. Includes a bracket to relocate work lights. Protects operator from small debris and is ideal for use with a hammer.

Available for Terex and Kubota Excavators.

**OPEN ROPS WIRE FRONT GUARD**

Easily bolts to ROPS frame with no welding required. Protects operator from small debris.

Available for Kubota Excavators.

**OPEN ROPS BAR STYLE FRONT GUARD**

Easily bolts to ROPS frame with no welding required. Protects operator from debris.

Available for Kubota Excavators.



SPECIALTY PRODUCTS



FORESTRY GRAPPLE



FEATURES

- Built to applications for maximum load capacities
- Exceptional handling speed and hydraulic power
- Easy-to-mount pin-on or quick change connections
- Hardened and chrome pins
- Tool cylinder control with continuous 360° rotation
- Concealed hydraulics
- Ideal for forest, mill loading, sorting, decking, hoe-chucking and yard applications

| | | | | | | | | |
|--------------|--------------|--------------|--------------|-------|---------|-------|-------|--------------|
| 02 mT | 03 mT | 05 mT | BH 13'-17' | 08 mT | BH 17'+ | 12 mT | 15 mT | 20 mT |
| 25 mT | 27 mT | 35 mT | 45 mT | 60 mT | 80 mT | | | |

TREE LENGTH GRAPPLE



FEATURES

- Designed to efficiently bunch, sort, load/unload and stack tree length wood
- Exceptional handling speed and torque
- Built to maximize load capacities
- Available tine configurations include 2/1

| | | | | | | | | |
|--------------|--------------|--------------|--------------|-------|---------|-------|-------|--------------|
| 02 mT | 03 mT | 05 mT | BH 13'-17' | 08 mT | BH 17'+ | 12 mT | 15 mT | 20 mT |
| 25 mT | 27 mT | 35 mT | 45 mT | 60 mT | 80 mT | | | |

EXCAVATOR MAT GRAPPLE



FEATURES

- Handle multiple mats
- Replaceable weld-on teeth
- Single/Dual MCD drive with continuous 360° rotation
- Quickly clean and pry up mats
- Pin-on or QC lugging
- Ideal for forestry, oil and gas, and construction applications

| | | | | | | | | |
|-------|-------|-------|------------|-------|---------|-------|-------|-------|
| 02 mT | 03 mT | 05 mT | BH 13'-17' | 08 mT | BH 17'+ | 12 mT | 15 mT | 20 mT |
| 25 mT | 27 mT | 35 mT | 45 mT | 60 mT | 80 mT | | | |

LOGGING GRAPPLES



FEATURES

- Designed and manufactured for rugged shovel logging applications
- Grapple arms designed with mounting lugs for optional bolt on quick change brush rake arms
- Standard on 52", 58" and 66" arms
- Easily removable guarding for access to all hydraulic components
- Large diameter, induction hardened alloy pins and bushings used in arms and cylinders
- Designed for high pressure hydraulic systems
- Easy maintenance

| | | | | | | | | |
|-------|-------|-------|------------|-------|---------|-------|-------|-------|
| 02 mT | 03 mT | 05 mT | BH 13'-17' | 08 mT | BH 17'+ | 12 mT | 15 mT | 20 mT |
| 25 mT | 27 mT | 35 mT | 45 mT | 60 mT | 80 mT | | | |

CABLE REELERS



FEATURES

- Rapid Reel Interchange without Ground Helper. "Lift & Go" Drive System
- Allows partial cable deployment with access to both couplers
- Drum system compatible with complete system - Fully Integrated
- Ruggedly constructed and designed for ease of maintenance
- Drilling and loading more with less downtime
- Configured to suit your application with integrated system options for wheel loaders, dozer mount, scoop tram or truck mount

DOZER BLADES



FEATURES

- A complete range of durable blades to mount on Track Type Tractors, Wheeled Dozers & Compactors, Wheel Loaders and Graders
- Available with high-grade liner wear packages, side plate protection, spill guards and bolt-on edges
- Optimal one blade profile for multiple applications:
 - - Slot Dozing
 - - Reclamation
 - - Stripping
 - - Tailings
- High strength, durable boxed construction
- Extreme wear properties
- Increased fuel efficiency
- Faster cycle times
- Improved undercarriage life
- Lugged to OEM standards
- SAE capacity rating

TIRE MANIPULATORS



FEATURES

- Safe and versatile
- Industry-proven reliability
- Tire fall back protection
- Manual central greasing for ease of maintenance
- Load holding valves
- Built to mount on your machine

**PERFORMANCE.
PARTNERSHIP.
SELECTION.**



STANLEY
Infrastructure

6430 SE Lake Rd.
Portland, OR 97222
833.723.1843
www.STANLEYInfrastructure.com



2022.09.0